

VX Pro Series

All-in-One Controller

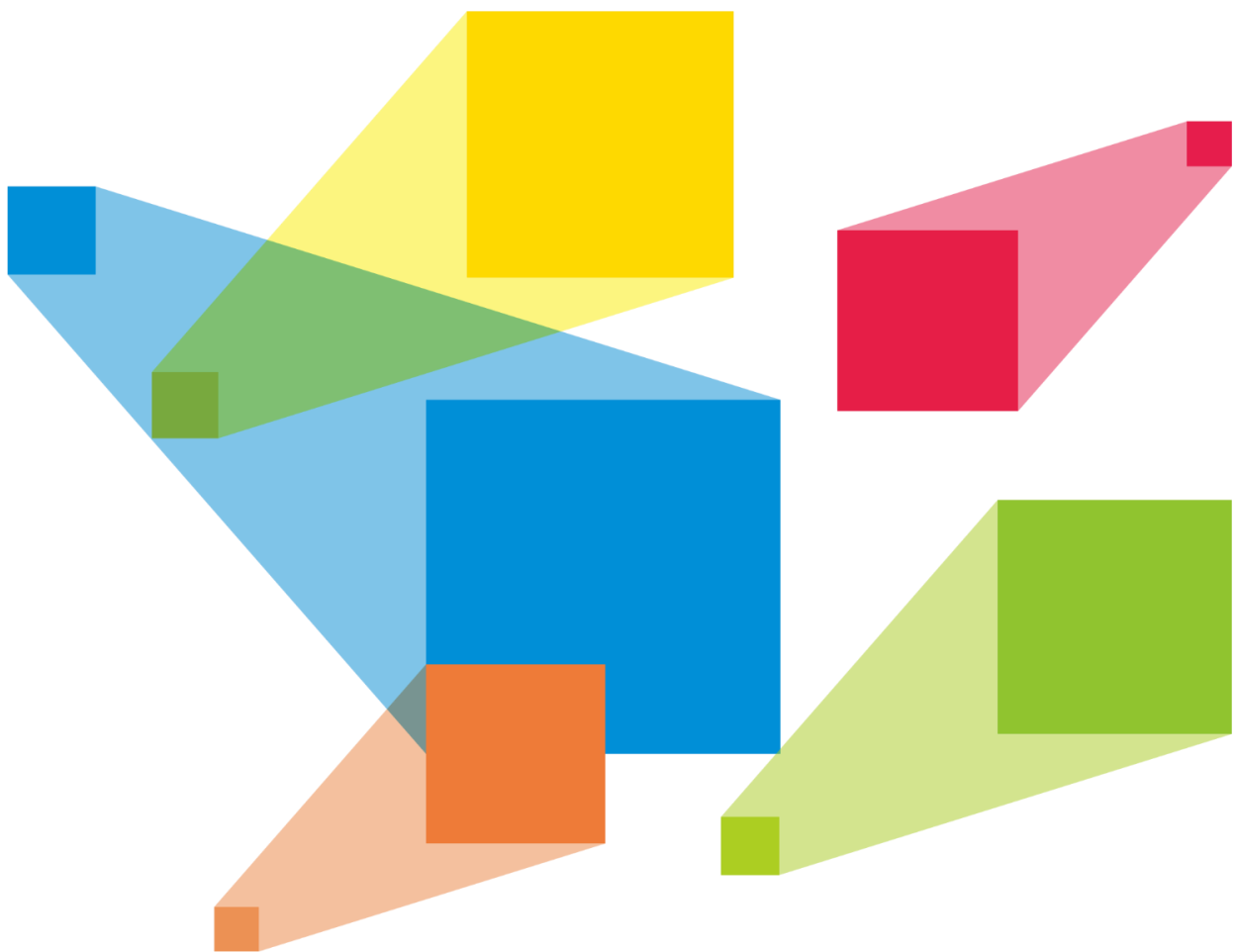

User Manual

Contents

| | |
|--|----|
| 1 Change History | 6 |
| 2 Applications..... | 7 |
| 3 Home Screen | 8 |
| 3.1 Home Screen | 8 |
| 3.2 Second Home Screen | 10 |
| 3.2.1 OPT Status Screen..... | 10 |
| 3.2.2 Fiber Converter Screen..... | 11 |
| 4 Menu Operations..... | 12 |
| 4.1 Screen Brightness..... | 12 |
| 4.2 Screen Configuration..... | 13 |
| 4.2.1 Quick Configuration | 13 |
| 4.2.2 Save to RV Card | 15 |
| 4.2.3 Mapping..... | 15 |
| 4.2.4 LED Screen Color..... | 16 |
| 4.3 Layer Settings | 18 |
| 4.3.1 Add Layers..... | 18 |
| 4.3.2 Set Layer Properties..... | 19 |
| 4.3.3 Input Crop..... | 21 |
| 4.4 Input Settings..... | 22 |
| 4.4.1 Switch Connector Capacity..... | 22 |
| 4.4.2 Set Input Resolution | 23 |
| 4.4.3 Import and Export EDID..... | 25 |
| 4.4.4 Configure InfoFrame Override Parameters..... | 26 |
| 4.4.5 Configure Mosaic Sources..... | 28 |
| 4.5 Preset Settings..... | 30 |
| 4.5.1 Save Presets | 30 |
| 4.5.2 Load Presets..... | 31 |
| 4.5.3 Delete Presets..... | 31 |
| 4.6 Display Control..... | 32 |

| | |
|---|----|
| 4.7 USB Playback..... | 34 |
| 4.7.1 USB Player..... | 34 |
| 4.7.2 Playback Settings | 35 |
| 4.8 Advanced Settings..... | 37 |
| 4.8.1 End-to-End Backup | 37 |
| 4.8.1.1 Device Backup..... | 37 |
| 4.8.1.1.1 Backup Between Devices..... | 37 |
| 4.8.1.1.2 Backup Between Ethernet Ports | 39 |
| 4.8.1.2 Input Backup | 41 |
| 4.8.1.3 Ethernet Port Backup Test | 43 |
| 4.8.2 Synchronization..... | 44 |
| 4.8.3 Audio Settings | 45 |
| 4.8.3.1 Set Audio Status..... | 47 |
| 4.8.3.2 Select Output Audio..... | 47 |
| 4.8.3.3 Set Output Volume..... | 48 |
| 4.8.4 Low Latency | 49 |
| 4.8.5 3D | 50 |
| 4.8.6 Working Mode..... | 52 |
| 4.8.6.1 Device Working Mode..... | 52 |
| 4.8.6.2 OPT Mode | 53 |
| 4.8.7 HDCP Status..... | 55 |
| 4.8.8 Monitor Settings | 55 |
| 4.9 System Settings..... | 56 |
| 4.9.1 Fn56 | |
| 4.9.2 Return to Home..... | 56 |
| 4.9.3 Diagnostics | 57 |
| 4.9.4 Export Logs | 57 |
| 4.9.5 Update Device | 58 |
| 4.9.6 Cascading ID | 58 |
| 4.9.7 About Us..... | 59 |
| 4.10 Factory Reset..... | 59 |
| 4.11 Communication Settings..... | 60 |
| 4.12 Language..... | 61 |

| | |
|---|----|
| 5 Software Control | 62 |
| 5.1 Software Installation and Connection | 62 |
| 5.1.1 Software Installation | 62 |
| 5.1.2 Software Connection..... | 62 |
| 5.2 Project Management..... | 63 |
| 5.2.1 Create New Projects..... | 63 |
| 5.2.2 Import Projects..... | 65 |
| 5.2.3 Export Projects..... | 66 |
| 5.3 Device Management | 66 |
| 5.3.1 Enter Device Configuration Page | 66 |
| 5.3.1.1 Online Devices..... | 66 |
| 5.3.2 Configure Device Properties..... | 68 |
| 5.3.2.1 Rename Device | 68 |
| 5.3.2.2 Switch Working Mode..... | 69 |
| 5.3.2.3 Configure IP Address..... | 70 |
| 5.3.2.4 Configure Sync Source..... | 71 |
| 5.3.2.5 Configure HDCP | 72 |
| 5.3.2.6 Configure Date and Time..... | 72 |
| 5.3.2.7 Configure Input Source Backup..... | 73 |
| 5.3.2.8 Reset to Factory Settings..... | 74 |
| 5.3.2.9 Restart Device | 75 |
| 5.3.3 Configure Input Properties | 76 |
| 5.3.3.1 View Input Source Info..... | 76 |
| 5.3.3.2 Set OPT Ports | 77 |
| 5.3.3.3 View OPT Source Info..... | 78 |
| 5.3.3.4 Set Input Connector Capacity | 79 |
| 5.3.3.5 Configure InfoFrame Override Parameters | 80 |
| 5.3.3.6 Configure EDID | 81 |
| 5.3.3.7 Import and Export EDID | 83 |
| 5.3.3.8 Configure Compatibility with Mac | 84 |
| 5.4 Screen Configuration..... | 85 |
| 5.4.1 Configure Screen Topology | 85 |
| 5.4.1.1 Configure Online Cabinets..... | 85 |

| | |
|---|-----|
| 5.4.2 Configure Screen Properties | 90 |
| 5.4.2.1 Rename Screens | 90 |
| 5.4.2.2 Configure Low Latency..... | 91 |
| 5.4.2.3 Set Canvas Size..... | 92 |
| 5.4.2.4 Configure Test Patterns..... | 93 |
| 5.4.2.5 Configure Output Color | 95 |
| 5.4.3 Configure Cabinet Properties | 96 |
| 5.4.3.1 View Cabinet Info..... | 96 |
| 5.4.3.2 Configure Cabinet Groups..... | 97 |
| 5.4.3.3 Configure Cabinet Positions | 98 |
| 5.4.3.4 Set Cabinets..... | 99 |
| 5.4.3.5 Configure Ethernet Port Backup | 100 |
| 5.5 Screen Settings..... | 101 |
| 5.5.1 Adjust Image Quality | 101 |
| 5.5.2 Adjust Output | 102 |
| 5.5.2.1 Configure 3D | 102 |
| 5.5.2.2 Check Load..... | 104 |
| 5.6 Layer Operations..... | 105 |
| 5.6.1 Add Layers..... | 105 |
| 5.6.2 Configure Video Source Properties | 107 |
| 5.6.3 Mosaic Source Settings..... | 107 |
| 5.6.3.1 View Mosaic Source Info | 107 |
| 5.6.3.2 Configure Mosaic Sources | 108 |
| 5.6.4 Configure USB Source Properties | 109 |
| 5.6.4.1 Play USB Files..... | 109 |
| 5.6.4.2 Configure Playback Parameters | 110 |
| 5.6.5 Configure Layer Properties..... | 112 |
| 5.6.5.1 Configure Basic Properties..... | 112 |
| 5.6.5.2 Crop Layer Sources..... | 114 |
| 5.6.6 Manage Presets..... | 115 |
| 5.7 Maintenance | 116 |
| 5.7.1 Device Maintenance | 116 |
| 5.7.2 Device Diagnostics..... | 118 |

| | |
|-------------------------------------|-----|
| 5.8 Software Settings..... | 119 |
| 5.8.1 Switch UI Language..... | 119 |
| 5.8.2 Export Logs | 119 |
| 5.8.3 Configure Device Backup | 119 |
| 5.8.4 Manage Cabinet Library | 121 |
| 5.8.5 Configure Preferences | 123 |
| 5.8.6 View Software Info..... | 124 |
| 6 Copyright | 125 |

1 Change History

| Document Version | Release Date | Description |
|------------------|--------------|---------------|
| V1.0.0 | 2024-12-10 | First release |

2 Applications

The application diagram takes the VX2000 Pro as an example.

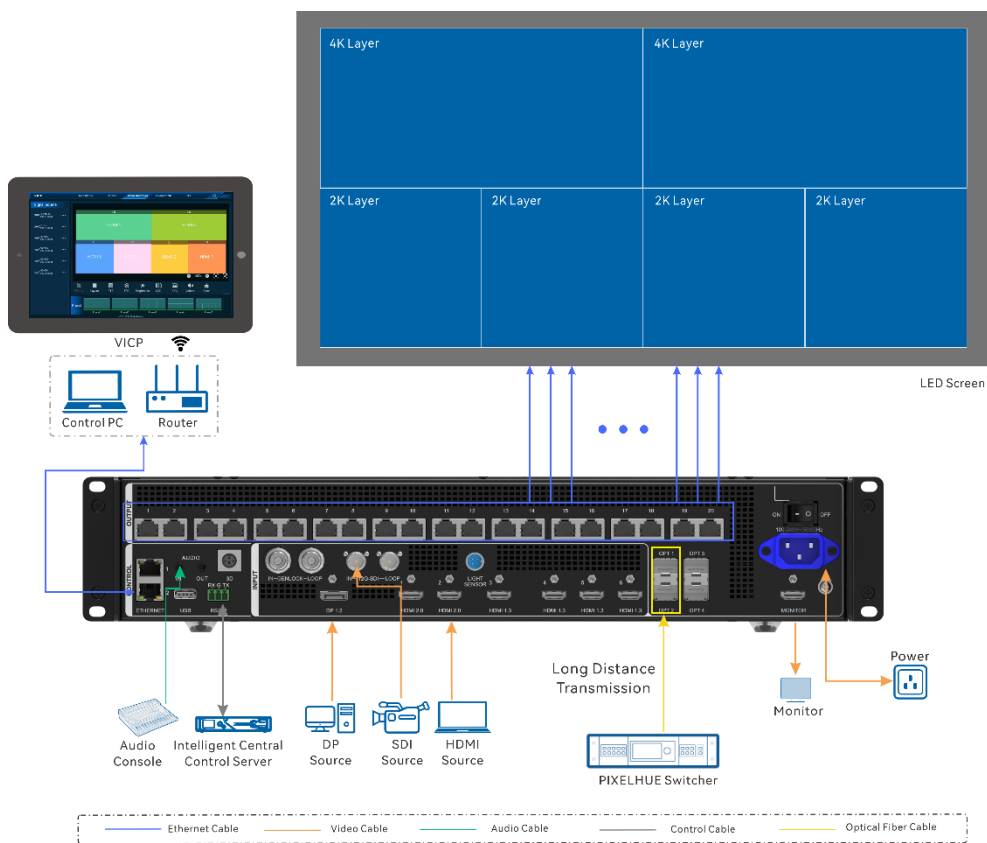

3 Home Screen

















This chapter takes the VX2000 Pro as an example.

3.1 Home Screen

Figure 3-1 Home Screen (VX2000 Pro)



| No. | Content | Description |
|-----|---|--|
| 1 | VX2000 Pro | The device name |
| | | <ul style="list-style-type: none"> • Hold down the knob and BACK button simultaneously to lock or unlock the front panel buttons. • After the buttons are locked, all the button operations will not take effect and the icon will appear. • After the buttons are unlocked, the icon will disappear. |
| | 192.168.0.10 | The device IP address |
| 2 | <ul style="list-style-type: none"> • Layer 1 • Layer 2 • Layer 3 | Displays the opened layer information, including the layer number, input source, input resolution and frame rate |
| 3 | 1920×1080@60 | Displays the resolution and frame rate of the configured screen. |
| | 100% | The screen brightness |

| No. | Content | Description | |
|-----|---|---|--|
| 4 |  | The Ethernet port is connected. | |
| |  | The Ethernet port is not connected. | |
| |  | <ul style="list-style-type: none"> The Ethernet port is connected and serves as the backup output port. When the backup icon at the bottom flashes, there is data transmission on the port. | |
| 5 | Synchronization |  | The sync function is enabled and the synchronization succeeded. |
| | |  | The sync function is not enabled. |
| | |  | The sync function is enabled and the synchronization is in progress. |
| | |  | The sync function is enabled but the synchronization failed. |
| | Display control |  | The output is black. |
| | |  | The test pattern is shown. |
| | |  | The output image is displayed. |
| | |  | The output image is frozen. |
| | Connection method |  | The device is connected to the control PC via an Ethernet port. |
| | |  | The device is not connected to the control PC. |
| | |  | The device is connected to the control PC via a USB cable. |
| | USB insertion status |  | USB drive inserted. |
| | |  | No USB drive inserted. |

3.2 Second Home Screen

3.2.1 OPT Status Screen

When the device is in **Video Controller** mode, this page may vary according to the device connected to the OPT port, as well as the OPT 3/4 working mode and the OPT loop mode.

- When a fiber converter is connected to OPT 1/OPT 2, the port is used as an output connector. The OPT status page displays the connection and backup statuses of the Ethernet ports on the fiber converter connected to the VX2000 Pro, as shown in [Figure 3-2](#).

Figure 3-2 OPT Status screen



- When a PIXELHUE video processor is connected to OPT 1/OPT 2, the port is used as an input connector. The OPT status page displays the resolution and frame rate of the accessed OPT source and the connection and backup statuses of the Ethernet ports on the fiber converter connected to the VX2000 Pro, as shown in [Figure 3-3](#).

Figure 3-3 OPT input



- When OPT loop mode is enabled, the OPT status page is shown as follows.

Figure 3-4 OPT Loop



Note



You can set the working mode of OPT 3 and OPT 4 to **Copy** or **Backup**. The OPT status screen page will display the set working mode.

3.2.2 Fiber Converter Screen

When the device working mode is set to **Fiber Converter**, OPT 1~4 are all used for input and Ethernet ports are used for output. OPT 1 and OPT 2 serve as the primary connectors, while OPT 3 and OPT 4 serve as backup ones. The fiber converter screen page displays the data transmission status of Ethernet ports on the fiber converter.

Figure 3-5 Fiber converter screen



- : There is data transmission on Ethernet port.
- : No data transmission on Ethernet ports

4 Menu Operations

Note

Knob:

- On the home screen, press the knob to enter the operation menu screen.
- On the operation menu screen, rotate the knob to select a menu item and press the knob to confirm the selection or enter the submenu.
- When a menu item with parameters is selected, you can rotate the knob to adjust the parameters. Please note that after the adjustment, you need to press the knob again to confirm the adjustment.

BACK: Exit the current menu or cancel an operation.

4.1 Screen Brightness

Screen brightness allows you to adjust the LED screen brightness in an eye-friendly way according to the current ambient illuminance. Besides, the brightness parameters can be saved to the receiving cards.

Prerequisites

The device is connected to a screen.

Screen Example

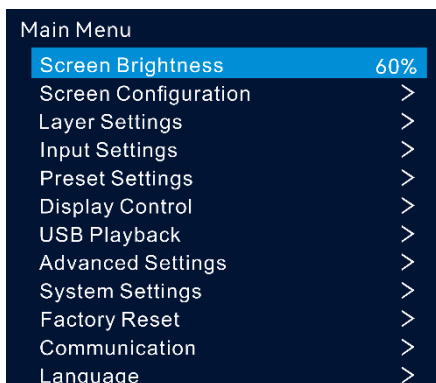

Operating Procedure

- Step 1 On the home screen, press the knob to enter the main menu screen.
- Step 2 Select **Screen Brightness** and press the knob to confirm the selection.
- Step 3 Rotate the knob to adjust the brightness value. You can see the adjustment result on the LED screen in real time. Press the knob to apply the brightness you set when you are satisfied with it.

4.2 Screen Configuration

Screen configuration allows you to perform the following operations, including configuring the screen, saving configuration to the receiving card and setting output mapping.

Figure 4-1 Screen configuration

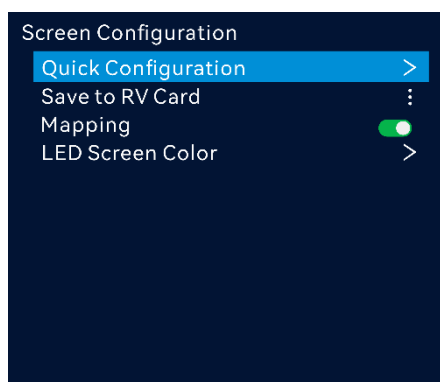

4.2.1 Quick Configuration

When the LED screen is a regular one composed of cabinets from the same batch, you can use the quick configuration function to configure the LED screen.

Prerequisites

- The LED screen must be a regular one.
- The cabinets of the screen must be regular cabinets with the same resolution.
- The following data flow settings are supported. During data flow settings, ensure that each port's physical connection is along the same direction and downward to the next one.
- During data flow settings, ensure that Ethernet Port 1 is at the beginning of the actual physical connection.

Figure 4-2 Data flow



Notes

- Cabinets loaded by Ethernet port 1 ≥ cabinets loaded by Ethernet port 2 ≥ ... ≥ cabinets loaded by Ethernet port n ("n" represents the maximum port number.)
- The number of cabinets loaded by each Ethernet port must be an integer multiple of **Cabinet Row Qty** or **Cabinet Column Qty** of the screen.
- The total pixels of the cabinets loaded by Ethernet port 1 cannot exceed 650,000.

Screen Example

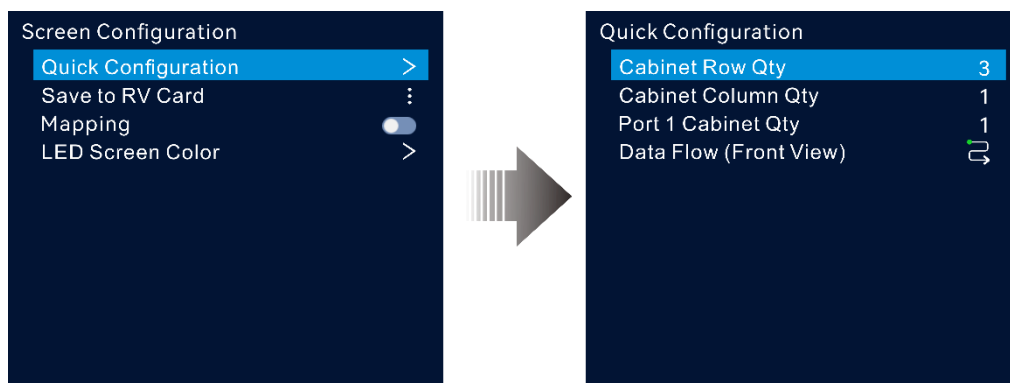

Operating Procedure

- Step 1 On the main menu screen, rotate the knob to go to **Screen Configuration > Quick Configuration** to enter the quick configuration screen.
- Step 2 Set **Cabinet Row Qty** and **Cabinet Column Qty** according to the cabinets' actual row and column quantities.
- Step 3 Rotate the knob to select **Port 1 Cabinet Qty** to set the quantity of the cabinets loaded by Ethernet port 1.
- Step 4 Rotate the knob to select **Data Flow (Front View)** and press the knob to confirm. Select a physical connection for the cabinets.

During data flow settings, you can see the result on the LED screen in real-time. If the entire screen displays content correctly, that is, no overlapping or repetition, press the knob to save the settings.

4.2.2 Save to RV Card

After the screen configuration information is sent to the receiving card, you can save the configuration to the card by using this function so that the configuration data will not be lost after a power failure.

Screen Example

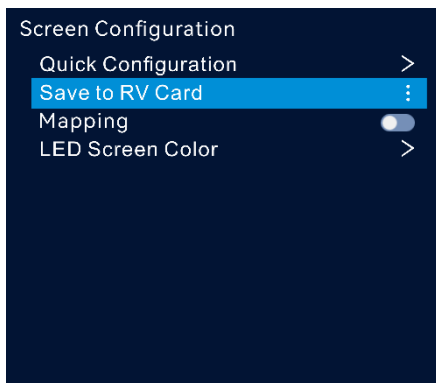

Operating Procedure

On the main menu screen, go to **Screen Configuration > Save to RV Card** and press the knob to confirm.

4.2.3 Mapping

Mapping is used to show the relations between the cabinets of the LED screen and the sending devices so that you can view or check the connections between the cabinets.

Notes

The receiving cards that are connected to the device must support the Mapping function. For the supported models of the receiving cards, please visit our official website at www.novastar.tech.

Screen Example

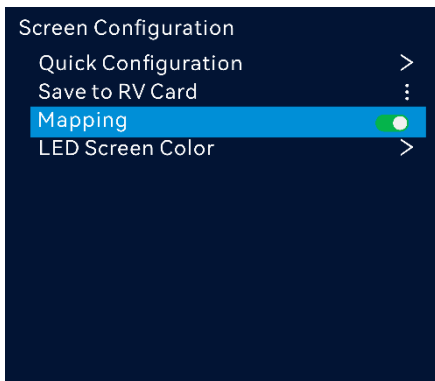

Operating Procedure

On the main menu screen, go to **Screen Configuration > Mapping** and turn on the function.

Figure 4-3 Mapping



Example: **S:01** stands for the sending card number, **P:01** stands for the Ethernet port number and **#001** stands for the cabinet number.

4.2.4 LED Screen Color

This function allows you to adjust the color temperature and Gamma value of the LED screen to make the images displayed on the screen more clear and vivid.

Screen Example

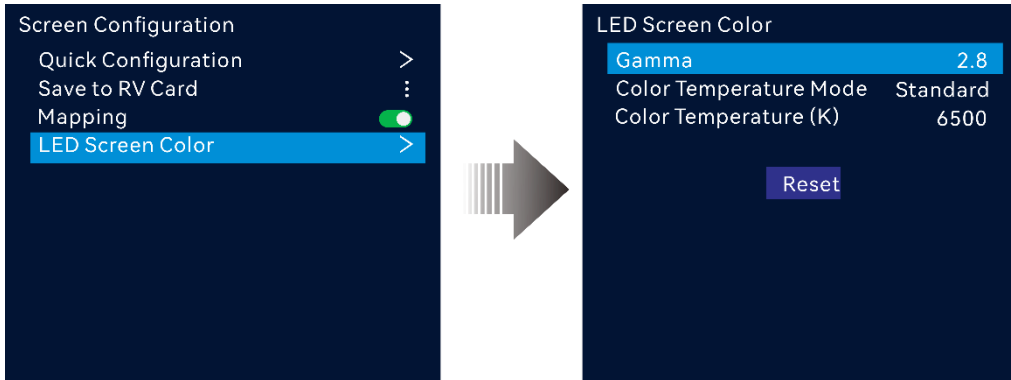

Operating Procedure

On the main menu screen, go to **Screen Configuration > More Settings** to enter the screen color settings screen.

- Select **Gamma** and press the knob to confirm. Rotate the knob to adjust the Gamma value and press the knob to confirm when you are satisfied with it.
- Rotate the knob to select **Color Temperature Mode** and press the knob to confirm. Rotate the knob to adjust the temperature mode, including **Standard, Cool, Warm** and **Custom**, and then press the knob to confirm when you are satisfied with it.

When **Custom** is selected, you can customize the color temperature value.

Parameter Descriptions

| Parameter | Description |
|------------------------|---|
| Gamma | Adjust the image distortion degree from the input to output. The greater the value is, the more distorted the image will be. The value ranges from 0.25 to 4.00 and defaults to 2.8. |
| Color Temperature Mode | Adjust the cool or warm degree of images displayed on the LED screen. When Custom is selected, you can customize the color temperature value. |

4.3 Layer Settings

4.3.1 Add Layers

Notes

The maximum number of layers that can be added depends on the connected device.

| Device Model | Number of Supported Layers (2K×1K) |
|--------------|------------------------------------|
| VX2000 Pro | 12 |

Screen Example

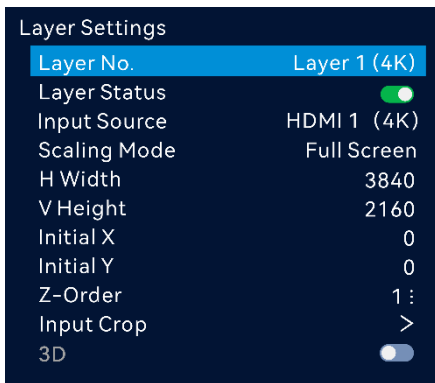

Operating Procedure

- Step 1 On the home screen, press the knob to enter the main menu screen.
- Step 2 Rotate the knob to select **Layer Settings** and press the knob to enter the layer settings screen.
- Step 3 Rotate the knob to select **Layer No.** and press the knob to display the layer list.

 **Note**

- In the layer list, both the current opened layers and the layers to be opened are displayed.
- Layer name displayed in the layer list: Opened layer: Layer n (capacity), unopened layer: Layer n, and “n” represents the layer number.

- Step 4 Rotate the knob to select the desired layer number and press the knob to confirm.
- Step 5 Rotate the knob to select **Layer Status** and press the knob to turn on the switch.

- Step 6 Rotate the knob to select **Input Source** and select the desired input source for the layer.
- Step 7 Rotate the knob to select other layer parameters and set them if needed. The layer parameter descriptions are shown in [Figure 4-4](#).

Figure 4-4 Layer parameter descriptions







- Step 8 Rotate the knob to select **Z-Order** and set the layer z-order.
The greater the priority number is, the higher priority the layer has.

4.3.2 Set Layer Properties

Parameter Descriptions

Table 4-1 Layer properties

| Menu | Description |
|--------------|--|
| Layer No. | The layer number |
| Layer Status | Open or close the layer  Note By default, layer 1 is opened and uses the first input source. |
| Input source | Select an input source for the current layer.  Note Press an input source button in the SOURCE area on the device front panel to quickly select an input source for the layer. |

| Menu | Description |
|--------------|---|
| Scaling Mode | <p>The layer supports the following three scaling modes.</p> <ul style="list-style-type: none"> • Full Screen: The layer image fills the whole screen. • Pixel to Pixel: The layer image is not scaled but displayed in the original size of the input source or the cropped source. • Custom: Customize the layer size and the output image is scaled according to the layer size. |
| H Width | <p>Set the layer size in the horizontal direction.</p> <p>The width value ranges from 64 to 131070.</p> |
| V Height | <p>Set the layer size in the vertical direction.</p> <p>The height value ranges from 64 to 131070.</p> |
| Initial X | <p>Set the horizontal distance between the top left corner of the layer and the top left corner of the screen.</p> <p>The value ranges from -250000 to 248080.</p> |
| Initial Y | <p>Set the vertical distance between the top left corner of the layer and the top left corner of the screen.</p> <p>The value ranges from -250000 to 248080.</p> |
| Z-Order | <p>The layer priority</p> <ul style="list-style-type: none"> • Up: Bring the selected layer forward. • Down: Send the selected layer backward. • Top: Bring the selected layer to the front. • Bottom: Send the selected layer to the back. |
| Input Crop | <p>Crop the input source image and display the cropped part on full screen.</p> <ul style="list-style-type: none"> • Status: Turn on or turn off the function. • H Width: The size of the copped part in the horizontal direction • V Height: The size of the copped part in the vertical direction. • Initial X: Set the start position for the cropping in the horizontal direction. The value defaults to 0. • Initial Y: Set the start position for the cropping in the vertical direction. The value defaults to 0. |
| 3D | <p>Turn on or turn off the function.</p> <ul style="list-style-type: none"> • On:  • Off:  |

4.3.3 Input Crop

This function allows you to crop the input source image and make the cropped part display on full screen.

Prerequisites

A fine signal is connected to the input connector.

Notes

- The status and capacity of the cropped source remain consistent with the original one.
- The input cropping and 3D functions cannot be enabled at the same time.

Screen Example

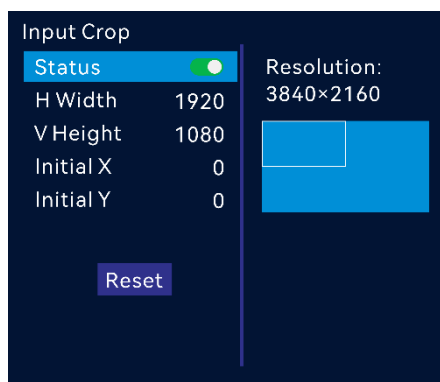

Operating Procedure

- Step 1 On the home screen, press the knob to enter the main menu screen.
- Step 2 Go to **Layer Settings > Input Source** and press the knob to display the input source list.
- Step 3 Rotate the knob to select the desired input source and press the knob to confirm.
- Step 4 Rotate the knob to select **Input Crop** and press the knob to enter the input source cropping screen.
- Step 5 Select **Status** and press the knob to turn on the function.
- Step 6 Rotate the knob to configure the cropping parameters and set them if needed. The cropping parameter descriptions are shown in [Table 4-1](#) and [Figure 4-5](#).

Figure 4-5 Input crop effect

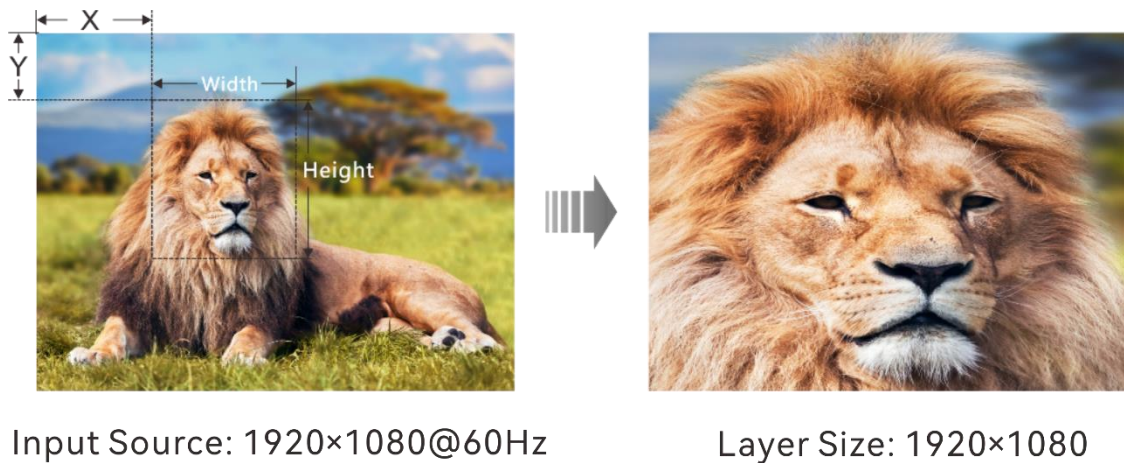

4.4 Input Settings

The input settings allow you to switch the input connector capacity, set input resolution and InfoFrame override parameters, as well as configure mosaic sources.

Figure 4-6 Input settings

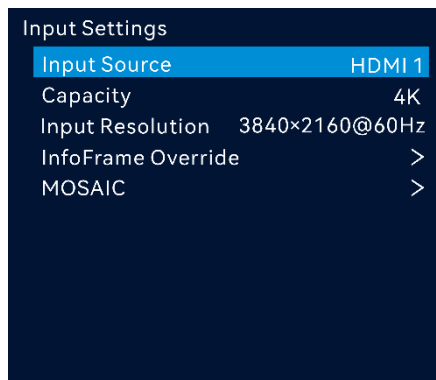

4.4.1 Switch Connector Capacity

Switch the input connector capacity to allow the device to calculate the number of layers that can be added based on the capacity.

Prerequisites

You have selected an input source.

Notes

Changing the connector capacity of the OPT source is not supported.

Screen Example

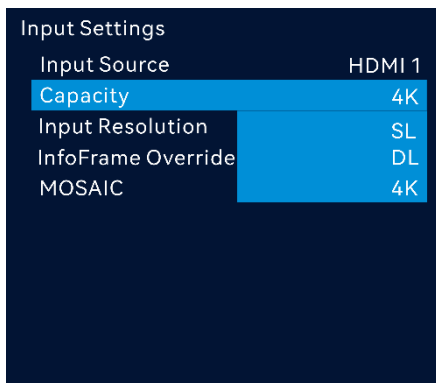

Operating Procedure

- Step 1 On the input settings screen, rotate the knob to select **Input Source** and press the knob to display the input source list.
- Step 2 Rotate the knob to select the desired input source and press the knob to confirm.
- Step 3 Rotate the knob to select **Capacity** and press the knob to display the capacity list.

Descriptions of the connector capacity:

- SL: 1920×1080@60Hz
- DL: 3840×1080@60Hz
- 4K: 3840×2160@60Hz

- Step 4 Rotate the knob to select the target capacity and press the knob to confirm.

4.4.2 Set Input Resolution

Set the input resolution and frame rate. The options include **Standard** and **Custom**.

Prerequisites

- The front-end device outputs the video source from the graphics card.

- You have selected an HDMI or DP source. SDI does not support this function.

Screen Example

Figure 4-7 Standard resolution

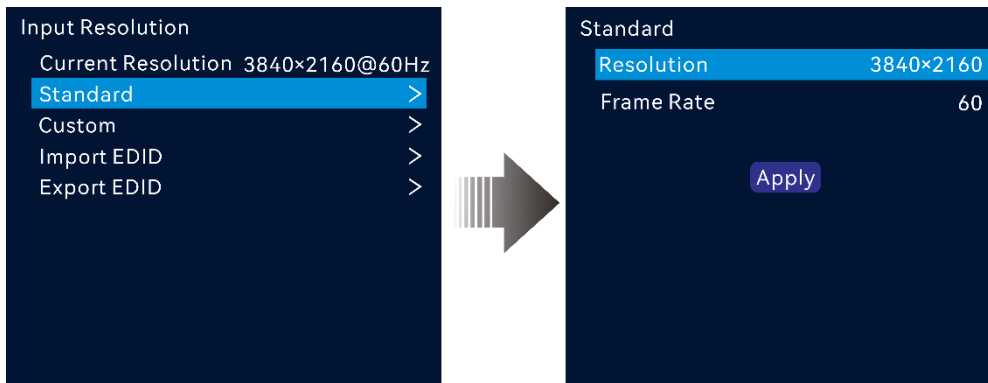
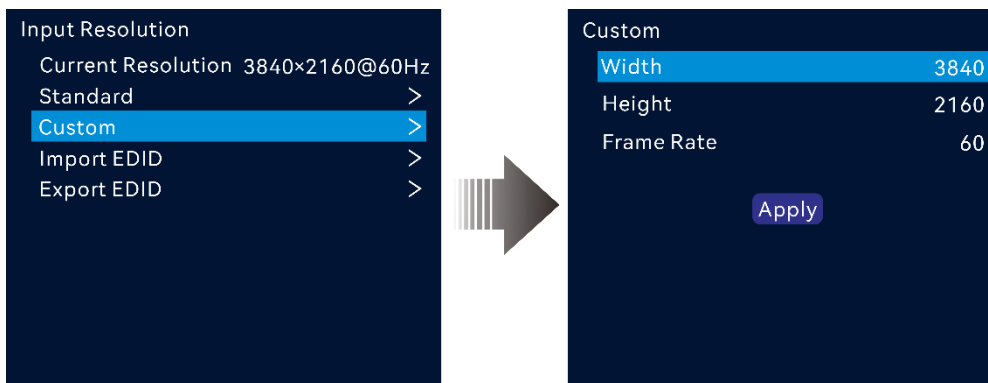

Figure 4-8 Custom resolution



Operating Procedure (Standard Res)

- Step 1 On the input settings screen, select the desired input source and press the knob to confirm.
- Step 2 On the input resolution settings screen, select **Standard**.
- Step 3 Rotate the knob to select **Resolution**, and press the knob to show the resolution list.
- Step 4 Rotate the knob to select the desired resolution from the list and then press the knob to confirm.
- Step 5 Rotate the knob to select the desired frame rate from the list and then press the knob to confirm.
- Step 6 Rotate the knob to select **Apply** and press the knob to complete the standard resolution settings.

Operating Procedure (Custom Res)

- Step 1 On the input settings screen, select the desired input source and press the knob to confirm.
- Step 2 On the input resolution settings screen, select **Custom**.
- Step 3 Rotate the knob to select **Width** and press the knob to confirm. Rotate the knob again to select the desired width and press the knob to confirm.
- Step 4 Rotate the knob to select **Height** and press the knob to confirm. Rotate the knob again to select the desired height and press the knob to confirm.
- Step 5 Rotate the knob to select **Frame Rate** and press the knob to show the frame list. Rotate the knob again to select the desired frame rate and press the knob to confirm.
- Step 6 Rotate the knob to select **Apply** and press the knob to complete the custom resolution settings.

4.4.3 Import and Export EDID

If you encounter a compatibility problem with an input connector, you can resolve it by importing a compatible EDID file into the device. You can also export an EDID file from the device and providing it to other devices or input connectors.

Prerequisites

- Before importing the EDID file, you have saved the file (.bin and .dat) to the root directory in an USB drive and inserted it into the device USB port.
- Before exporting the EDID file, you have inserted an USB drive into the device USB port.
- You have selected an accessed input source. SDI connector does support this function.

Notes

- Each input connector supports importing one EDID file only.
- Once the EDID file is imported, the input connector will recognize and apply the parameters from the file.

Screen Example

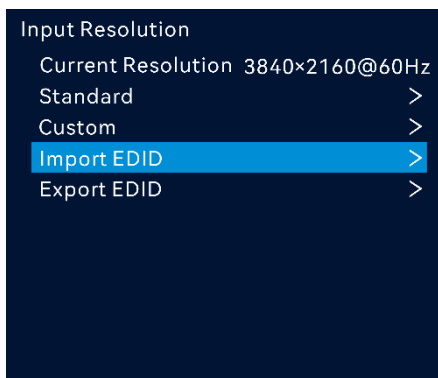

Operating Procedure (Import EDID)

- Step 1 On the input resolution settings screen, rotate the knob to select **Import EDID** and press the knob to enter the EDID file list screen.
- Step 2 Select the desired file and press the knob to confirm
- Step 3 In the popup dialog, select **OK** to import the EDID file.

Operating Procedure (Export EDID)

- Step 1 On the input resolution settings screen, rotate the knob to select **Export EDID** and press the knob to enter the EDID file exporting screen.
- Step 2 Select the file format (.bin or .dat) and press the knob to confirm.
- Step 3 Select **Apply** to apply the parameters saved in the file.

Note

If you need to modify the content of an imported EDID file, just modify it and then re-import it to overwrite the original one.

4.4.4 Configure InfoFrame Override Parameters

Set the InfoFrame override parameters for the input source, allowing the device to use them during calculations. This won't alter the input source's original parameter values.

Parameter Description

You have selected an HDMI or DP source. SDI does not support this function.

Screen Example

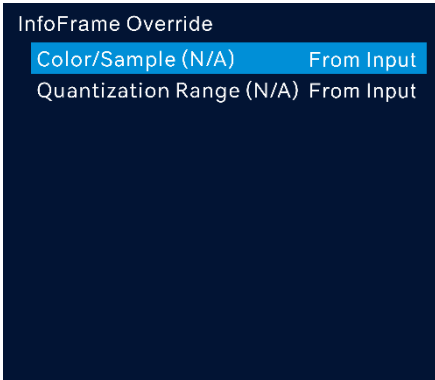

Operating Procedure

- Step 1 On the input settings page, rotate the knob to select **InfoFrame Override** and press the knob to enter the corresponding screen.
- Step 2 Rotate the knob to set the color/sample of the input source and press the knob to confirm.
- Step 3 Rotate the knob to set the quantization range of the input source and press the knob to confirm.

Parameter Descriptions

| Menu | Description |
|--------------------|--|
| Color/Sample | The sampling format of the input |
| Quantization Range | <p>The quantization range of the input</p> <p>The supported options include From Input, Limited and Full.</p> <p> Note</p> <p>Select From Input and the device will read the attribute values that come with the input source.</p> |

4.4.5 Configure Mosaic Sources

Both HDMI and OPT sources support mosaicing.

Notes

- Only the VX2000 Pro supports this function.
- Only the input sources of the same connector type support mosaicing, and the frame rates of sub-source must be the same.

Screen Example

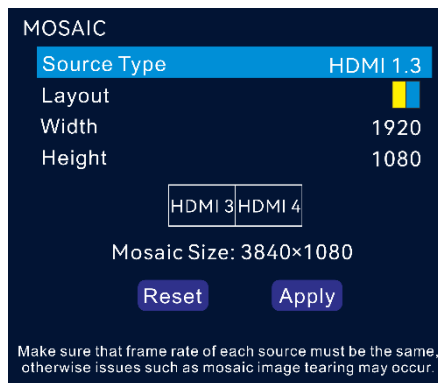





















Operating Procedure

- Step 1 On the input settings screen, rotate the knob to select **MOSAIC** and press the knob to enter the mosaic source settings screen.
- Step 2 Rotate the knob to select **Source Type** and press the knob to confirm.
- Step 3 Select the desired mosaic layout.
- Step 4 Set **Width** and **Height** for each mosaic area.
 - If the input source width or height is less than the width or height value you set, the blank area will be filled with solid black.
 - If the input source width or height is larger than the width or height value you set, the input source image will be cropped. The cropping takes the top left corner of the input source image as the reference point and then crops the image according to the set width and height values.
 - The total width and height of the mosaic source will be displayed.

- Step 5 Rotate the knob to select the mosaic layout area and press the knob to select sub-sources of each mosaic area.
- Step 6 Rotate the knob to select **Apply** to make the settings take effect; otherwise, select **Reset** to reset the settings to defaults.

Parameter Descriptions

| Parameter | Description |
|-------------|---|
| Source type | <p>The connector type of the sub sources</p> <p>The supported options include HDMI 2.0, HDMI 1.3 or OPT.</p> <p> Note</p> <p>Each OPT port supports transmission of 2x SL or 1x DL source.</p> |
| Layout | <p>The mosaic layout</p> <p>The layout varies depending on the source type.</p> <ul style="list-style-type: none"> • For HDMI 2.0, three layouts are supported: "", "" and "" • For HDMI 1.3, eight layouts are supported: "", "", "", "", "", "", "" and "" • For OPT, eight layouts are supported: "", "", "", "", "", "", "" and "" |
| Width | <p>The width of the individual mosaic area</p> <p>Default value: 1920 pixels</p> |
| Height | <p>The height of the individual mosaic area</p> <p>Default value: 1080 pixels</p> |
| Mosaic Size | <p>The size of the mosaic source</p> <ul style="list-style-type: none"> • Max. width: 8192 pixels • Max. height: 8192 pixels • Max. width and height: 4096×2160 |

 **Note**

The mosaic source capacity depends on the max capacity and number of sub-sources, that is, the capacity of a mosaic source composed of two DL sub-sources or SL+4K sub-sources is 4K.

4.5 Preset Settings

A preset is a set of parameters that save the layer and layer-related information. The VX Pro series supports 256 user-defined presets. After a preset is saved, you can load the preset simply by its name. The preset operations include **Save**, **Load** and **Delete**.

Screen Example

Figure 4-9 Preset settings

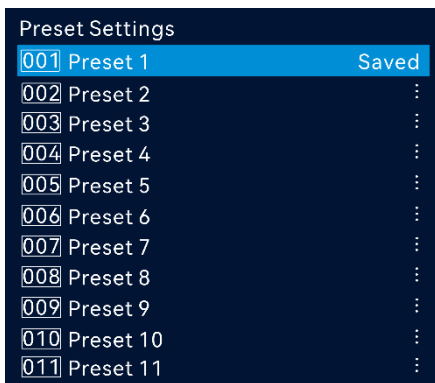

4.5.1 Save Presets

After the layer settings, you can save those settings as a preset.

Screen Example

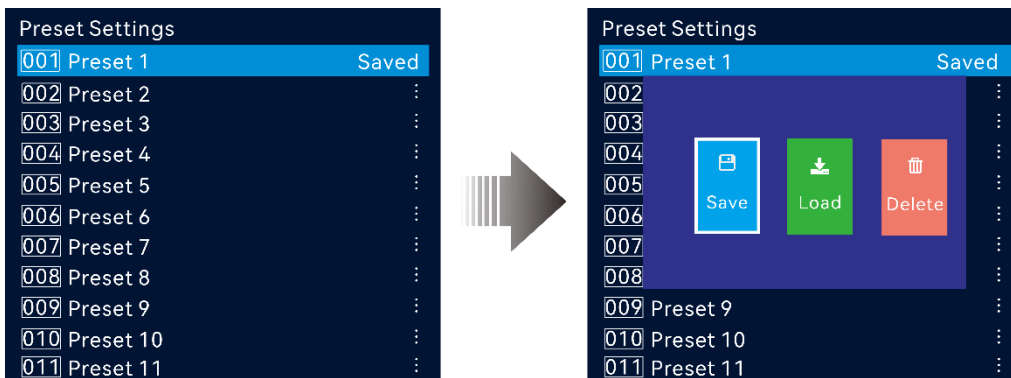

Operating Procedure

Step 1 On the preset settings screen, rotate the knob to select a preset.

Step 2 Press the knob to open the preset operations window.

Step 3 Rotate the knob to select Save and press the knob to save the layer settings to this preset.

After a preset is saved, the preset status on the right side changes to **Saved**.

4.5.2 Load Presets

This operation allows you to send a saved preset to an LED screen.

Screen Example

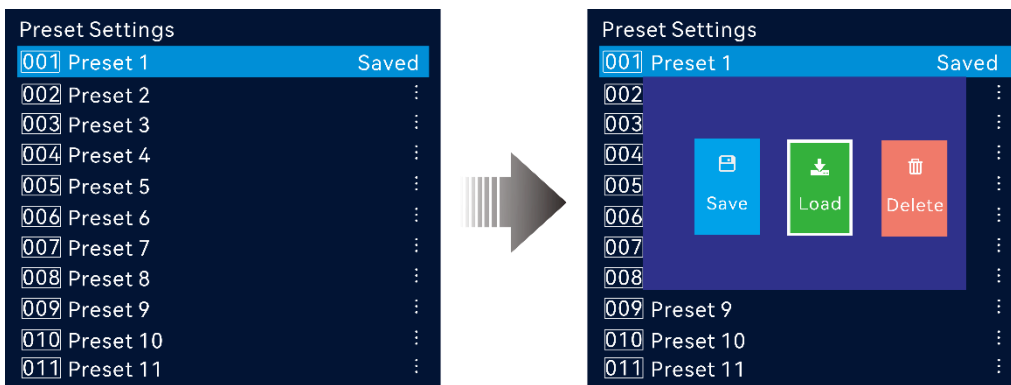

Operating Procedure

Step 1 On the preset settings screen, rotate the knob to select a saved preset.

Step 2 Press the knob to open the preset operations window.

Step 3 Rotate the knob to select **Load** and press the knob to load the preset.

After a preset is loaded, the preset status on the right side changes to **In Use**.

 **Note**

Press the **PRESET** button on the front panel to quickly enter the preset setting screen. You can press a number button to quickly load the corresponding preset.

4.5.3 Delete Presets

This operation allows you to clear the data saved in the preset. The preset name will not be cleared.

Screen Example

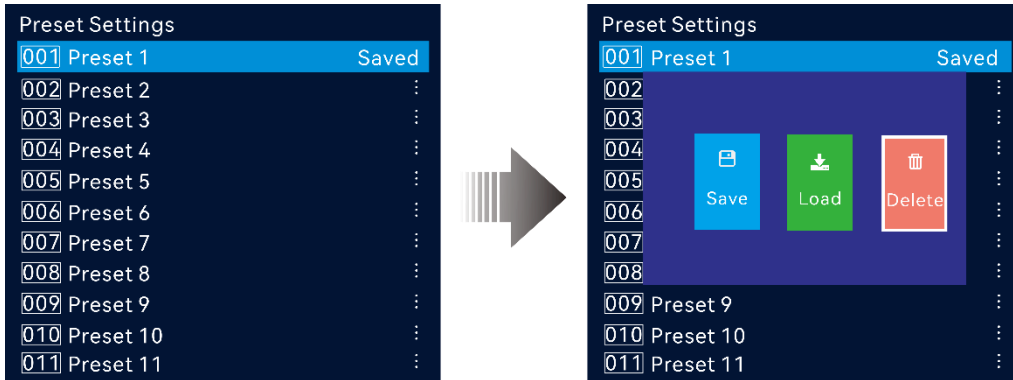

Operating Procedure

- Step 1 On the preset settings screen, rotate the knob to select a saved preset.
- Step 2 Press the knob to open the preset operations window.
- Step 3 Rotate the knob to select **Delete** and press the knob to open a confirmation window.
- Step 4 Rotate the knob to select **Yes** and press the knob to delete the preset.

4.6 Display Control

Notes

If the freeze or FTB function is turned on, the test pattern function is unavailable.

Screen Example

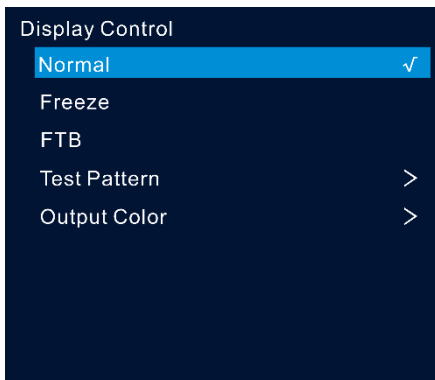

Parameter Descriptions

| Menu | Sub-Menu | Description |
|--------------|---------------|--|
| Normal | - | Display the content of the current input source. |
| Freeze | - | Freeze the current frame of the output image. |
| FTB | - | Make the output image fade to black. |
| Test Pattern | Pure Color | The pure color test pattern |
| | Gradient | The gradient test pattern |
| | Grid | The grid test pattern |
| | Brightness | The brightness of the test pattern |
| | Spacing Level | Set the spacing between different color areas. If a multi-color test pattern is selected, this parameter is available. |
| | Spacing (px) | Set the spacing between the lines. If a grid test pattern is selected, this parameter is available. |
| | Line Width | Set the width of the grid lines. If a grid test pattern is selected, this parameter is available. |
| | Speed | Set the moving speed of the lines. If a grid test pattern is selected, this parameter is available. |
| Output Color | Brightness | The shading of lights in the image Adjust the brightness value either as a whole or individually adjust the RGB components. |
| | Contrast | The ratio of the luminance of the brightest color to that of the darkest color Adjust the contrast value either as a whole or individually adjust the RGB components. |
| | Saturation | The color purity of the image The higher the value, the more vivid the color. |
| | Hue | The relative degree of how bright or dark the image is |

4.7 USB Playback

Play images or videos saved in a USB drive and configure the playback parameters. A USB source can be used as a layer source.

The models of devices that support USB playback and the corresponding output resolutions for USB sources are listed below.

| Device Model | USB Source Resolution |
|--------------|-----------------------|
| VX2000 Pro | 3840×2160@60Hz |

 **Note**

Press the desired layer button in the **LAYER** area on the device front panel and then press the **U-DISK** button to use a USB source to open a layer.

4.7.1 USB Player

Prerequisites

A USB drive has been inserted and recognized in the U-DISK connector on the front panel.

Notes

Up to 128 files can be displayed in the playlist and the size of each file cannot exceed 128 GB.

Screen Example

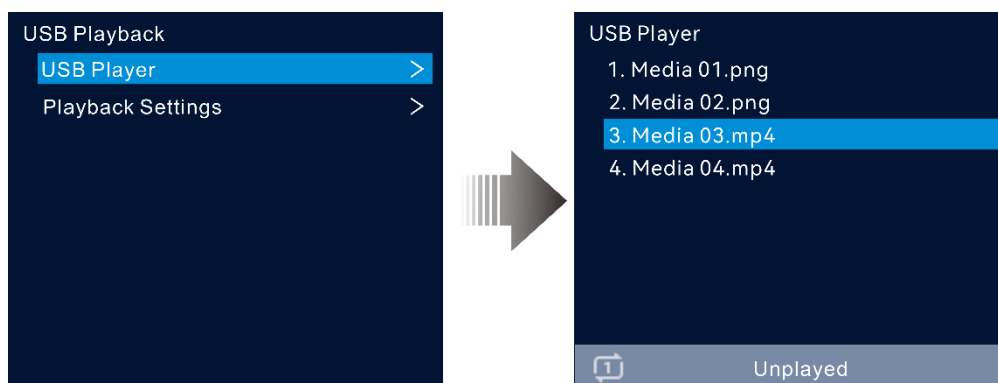

Operating Procedure

Step 1 On the main menu screen, go to **USB Playback > USB Player** to enter the USB player screen.

Step 2 Rotate the knob to select the desired the file and press the knob to play the file or stop the playback.

The items displayed on this screen are as follows.

- Media files in compatible formats
- The playback mode
- The playback status
- The volume level

4.7.2 Playback Settings

Configure the playback-related parameters.

Screen Example

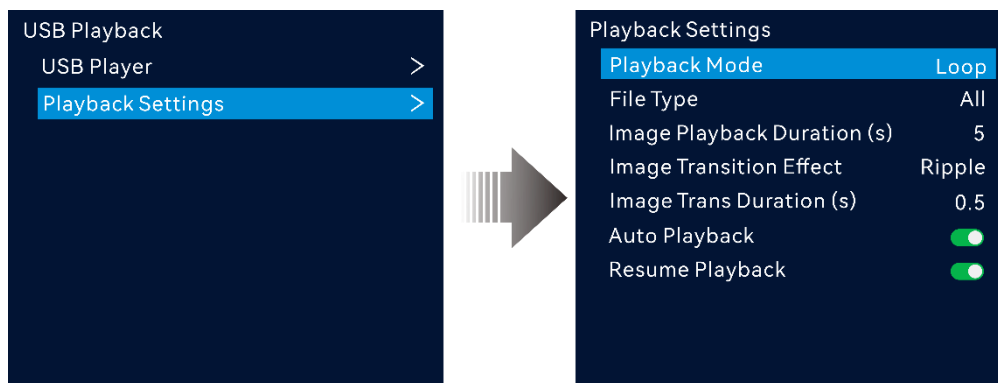





Limitations

- Single-partition USB drive supported
- File system: NTFS, FAT32 and exFAT
- Max. width and height of media files
Width: 3840 pixels, height: 2160 pixels
- Picture format: jpg, jpeg, png and bmp
- Decoded image resolution: 3840×2160 or lower

- Video format: mp4
- Video coding: H.264, H.265
- Max. video frame rate:
H.264: 3840×2160@30fps, H.265: 3840×2160@60fps
- Audio coding: AAC-LC
- Audio sampling rate: 8kHz, 16kHz, 44.1kHz, 48kHz

Parameter Descriptions

| Parameter | Description |
|-----------------------------|---|
| Playback Mode | <p>The playback mode of the file</p> <ul style="list-style-type: none"> • Loop: Play the files in the playlist in order. Once the playback of the last file is completed, replay the first file. • Play in Order: Play the files in the playlist in order. Once the playback of the last file is completed, the screen will display a black image and the playback will stop. • Repeat One: Loop playback of the current file. |
| File Type | <p>The type of the playback file</p> <ul style="list-style-type: none"> • Video • Image • All: Video and Image <p> Note</p> <p>After the file type is selected, only the file of the selected type will be displayed in the playlist.</p> |
| Image Playback Duration (s) | <p>The duration of the image playback</p> <p>The value ranges from 1 to 60 and it defaults to 5. (Unit: s)</p> |
| Image Transition Effect | <p>The trans effect of the image</p> <p>Supported trans effect: Ripple, zoom in, push, flip, blinds, H wipe, V wipe, cube, dissolve, grid, swapping, scroll, fade in/out, twirl, heart trans, curtains, perspective triangle, disappear, bounce, star rotation</p> |
| Image Trans Duration (s) | <p>The trans duration of the image</p> <p>The value ranges from 0.5 to 2 and it defaults to 0.5. (Unit: s)</p> |
| Auto Playback | <p>Set whether to automatically play the USB files after the device is powered off and then power on with a USB drive inserted.</p> |

| Parameter | Description |
|-----------------|--|
| | <ul style="list-style-type: none">  On <p>If Resume Playback not enabled, replay the files in the playlist in order; If enabled, replay the file being played before power failure from the beginning.</p> <ul style="list-style-type: none">  Off |
| Resume Playback | <ul style="list-style-type: none"> On: If a file is playing before the device power failure, enabling this function allows to replay the file from beginning after the device is powered on with a USB drive inserted. Off: Replay the files in the playlist in order. <div style="background-color: #f0f0f0; padding: 5px; margin-top: 10px;"> <p> Note</p> <ul style="list-style-type: none"> Enabling Resume Playback will also activate the Auto Playback feature at the same time. After Resume Playback is enabled, if the file being played before power failure cannot be found, the files will be played from the beginning of the playlist in order. </div> |

4.8 Advanced Settings

4.8.1 End-to-End Backup

The end-to-end backup is supported, including device backup, input source backup and Ethernet port backup test, stable and reliable.

4.8.1.1 Device Backup

The backup between devices and Ethernet ports are both supported.

4.8.1.1.1 Backup Between Devices

Device backup allows you to set the backup relationship between two devices. You can set one of the devices as the primary device or the backup device. When the primary device has a problem or the primary device's Ethernet cable fails, the backup device will take over the responsibilities of the primary device seamlessly and continue to work well to ensure the LED screen will not go black.

Prerequisites

- Before creating a backup relation, make sure that both the primary and backup devices are on the same LAN.
- In a backup relation, the models and device versions of the primary and backup devices must be the same.

Notes

- You have three options to create a backup relation: NovaLCT, Unico, or the device LCD menu. However, be aware that these methods do not synchronize with each other. Using more than one can lead to data problems. To prevent issues, choose only one method for setting up your backup. If you do mix them, you'll need to reset the device to factory settings and start over with just one method.
- In the device backup mode, the quantity of the cabinets loaded by each Ethernet port on both the primary and backup devices must be the same, but their data flow must be in a reversed way.

Hardware Connections

The diagram takes the VX2000 Pro as an example.

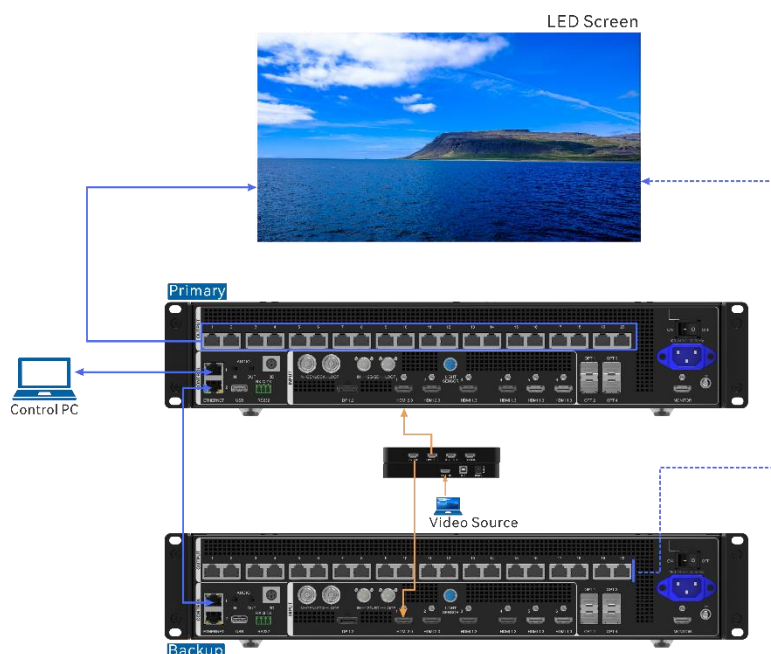

Screen Example

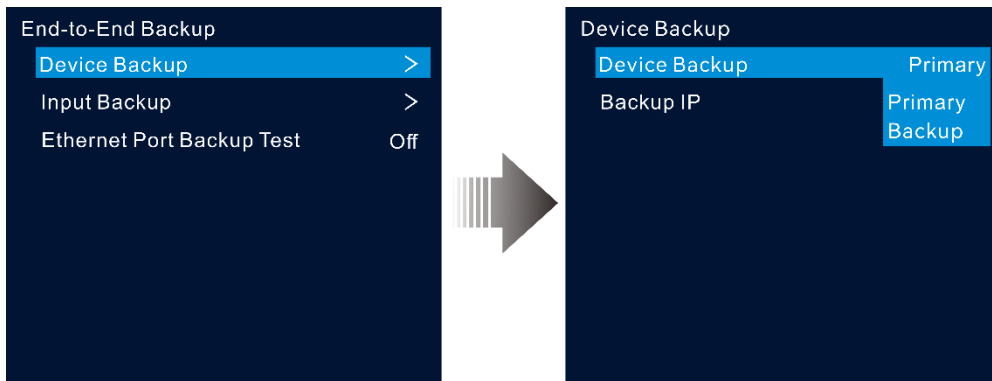

Operating Procedure

Step 1 On the main menu screen, go to **Advanced Settings > End-to-End Backup > Device Backup** to enter the device backup screen.

The available devices on the same LAN will be automatically searched.

Step 2 Set the primary device.

Step 3 Rotate the knob to select **Backup IP** and press the knob to display the backup IP list. Select the desired IP address of a device to be set as a backup one.

Note

After a backup relation is created, the configuration parameters (except communication settings) of the primary device will be automatically synchronized to the backup device.

4.8.1.1.2 Backup Between Ethernet Ports

Ethernet port backup allows you to set the backup relationship between two Ethernet ports. When the primary port has a problem or the primary port's Ethernet cable fails, the backup port will take over the responsibilities of the primary port seamlessly and continue to work well to ensure the LED screen will not go black. When setting the backup between the Ethernet ports, you need to complete it in NovaLCT.

Hardware Connections

This diagram takes the VX2000 Pro as an example.

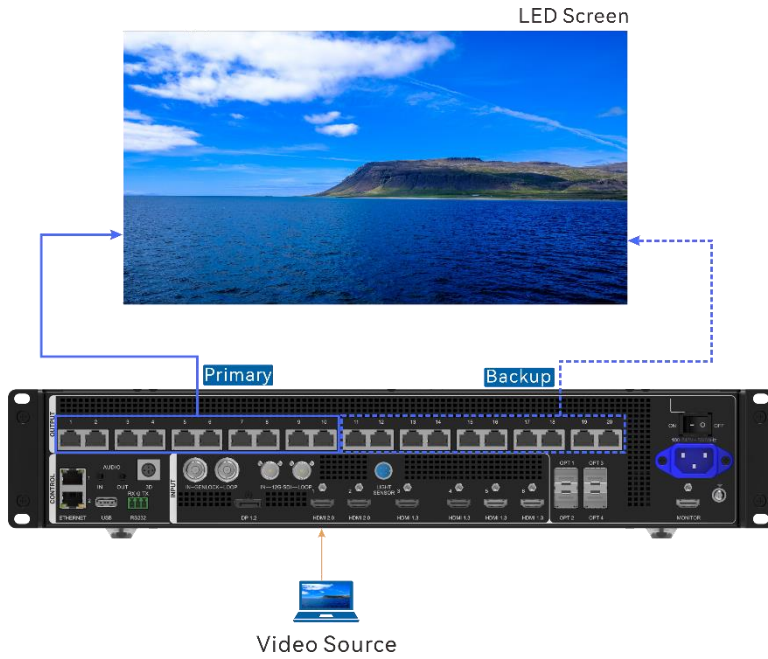

Operating Procedure

- Step 1 Run the NovaLCT software. On the menu bar, go to **User > Advanced Synchronous System User Login**. Enter the password and click **Login**.
- Step 2 Click **Screen Configuration** to enter the screen configuration page.
- Step 3 Click **Next** to enter the screen configuration page.

Figure 4-10 Screen configuration

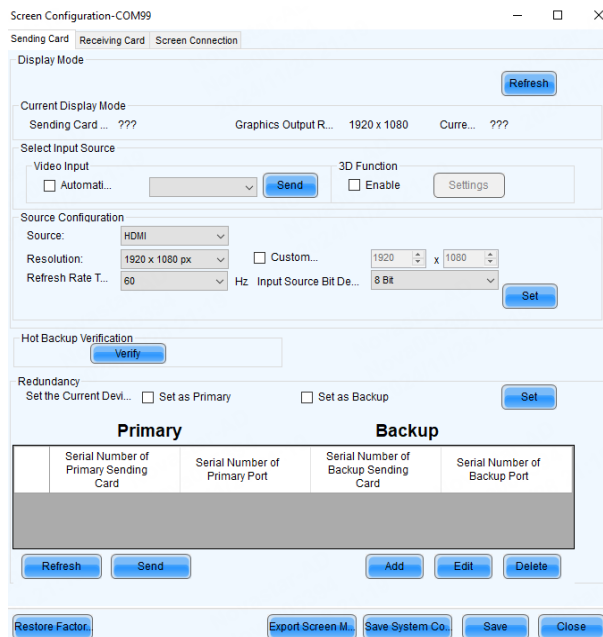

- Step 4 Select the **Sending Card** tab, and then click **Add** in the **Redundancy** area.

Step 5 Set the serial numbers of both the primary device and backup device to **1**.

Step 6 Set the serial number of the primary port and the serial number of the corresponding backup port.

Figure 4-11 Ethernet port backup

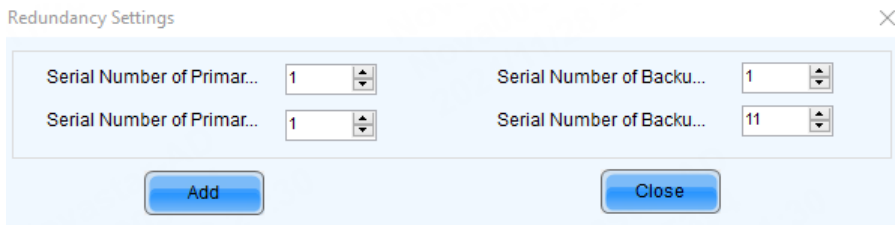

Step 7 Click **Add** to complete the backup settings of an Ethernet port, and the system will automatically list the primary ports and backup ports.

Figure 4-12 Primary Ethernet ports



Step 8 Repeat [Step 6](#) and [Step 7](#) to complete the backup settings for other Ethernet ports.

4.8.1.2 Input Backup

Input backup allows you to set the backup relationship between two input sources. When one input source has a problem or the input connector fails, the backup source will be used seamlessly and continue to work well to ensure the LED screen will not go black.

Notes

Input backup rules:

- In each backup group, two input sources serve as the backup for each other.
- Only the source from the same type of input connector can be set as the backup source.
- Each primary or backup source can have only one backup or primary source.
- Restrictions on input backup functions:

Input sources A and B form a hot backup group. The current input source of the layer is input source A.

- Input A: No signal. Input B: Signal

The layer input source is switched to input B automatically. When input A resumes and input B still has a signal and **Primary Source Preferred** is not enabled, the layer input source will not be changed.

- Input A: No signal. Input B: Signal

The layer input source is switched to input B automatically. When input A resumes, but input B does not have a signal, the layer input source will be changed to input A.

- Input A: No signal. Input B: No signal

The layer input source will not be changed.

- Input A: Signal. Input B: No signal

If you manually switch the layer input source to input B, the source will automatically switch to input A.

Screen Example

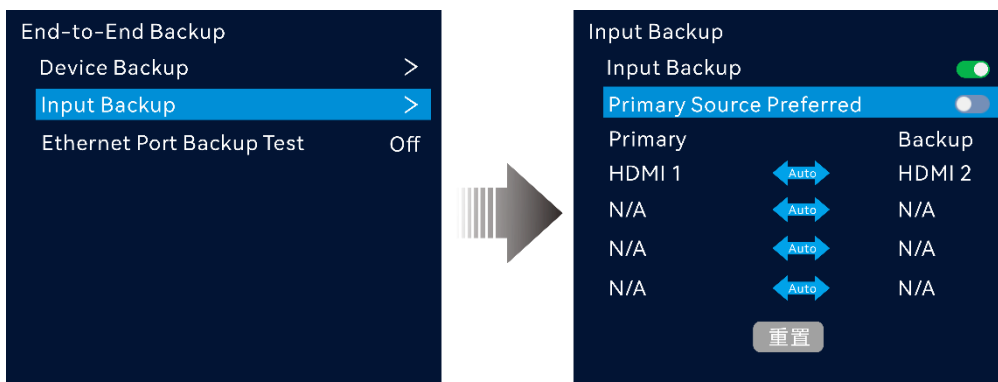

Operating Procedure

- Step 1 On the main menu screen, go to **Advanced Settings > End-to-End Backup > Input Backup** to enter the input backup settings screen.
- Step 2 Rotate the knob to select **Input Backup** and press the knob to turn on the function.
- Step 3 Rotate the knob to select the desired primary input source on the left side.
- Step 4 Rotate the knob to select the desired backup input source on the right side.
- Step 5 (Optional) Set the primary source preferred.
 - On: The primary source will always be used if there is a signal. When the primary source fails, the layer input source is switched to the backup one automatically. Once the primary source resumes, the layer input source seamlessly switches back to the primary source.
 - Off: The layer input source will be switched to the primary source only when the backup one fails and the primary one has a signal.

4.8.1.3 Ethernet Port Backup Test

Test whether the pre-stored images, backup Ethernet ports and devices take effect without plugging and unplugging the Ethernet cables.

Prerequisites

The pre-stored images, primary and backup Ethernet ports or primary and backup devices have been configured.

Screen Example

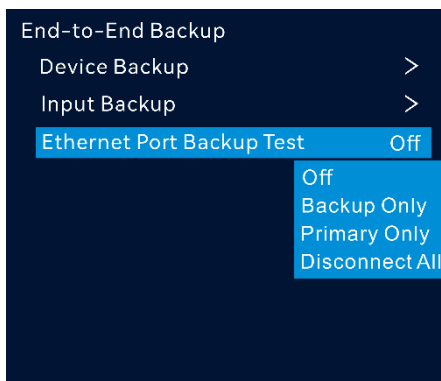

Parameter Descriptions

| Parameter | Description |
|-----------------|--|
| Off | Enable the output of all the Ethernet ports on the current device to complete the test. |
| Backup Only | Disable the output of the primary Ethernet port on the current device to test whether the backup port or device takes effect. |
| Primary Only | Disable the output of the backup Ethernet port on the current device to test whether the output of the primary port is normal. |
| Disconnect All: | Disable the output of all the Ethernet ports on the current device to test whether the pre-stored image takes effect. |

4.8.2 Synchronization

This function allows you to select a synchronization signal to synchronize all the cascaded device units or synchronize the primary and backup devices to display the output images of all the units in sync.

Notes

- The input source with or without signal can be used as a sync source. When a no signal source is used, the sync fails.
- Synchronizing to a DP source is supported by the VX2000 Pro only.
- Before enabling the Genlock sync function, make sure the sync signal has been connected to the Genlock connector of the device.

Screen Example

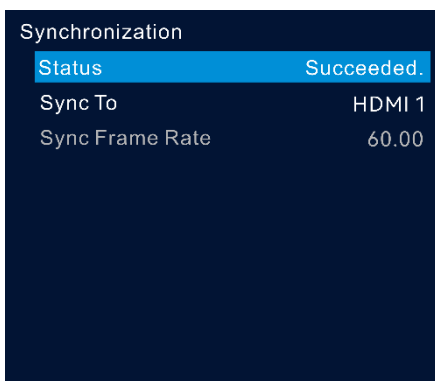

Operating Procedure

- Step 1 On the main menu screen, go to **Advanced Settings > Synchronization** to enter the synchronization settings screen.
- Step 2 Rotate the knob to select **Sync To** and press the knob to display the sync source list. The options include **Internal**, **HDMI X/DP/SDI** and **Genlock**. ("X" represents the input source number and its format may vary depending on the actual setup.)
- Internal: The frame rate of the output image
 - HDMI X/DP/SDI: Sync with the frame rate of the selected input source. After a sync source is selected, the sync frame rate will be displayed.
 - Genlock: Sync with the frame rate of the Genlock signal.
- Step 3 (Optical) If **Internal** is selected, you can manually set the output frame that defaults to 60Hz. Once the synchronization is successful, the screen will show **Succeeded**.

4.8.3 Audio Settings

This function allows you to set the audio status, output audio and volume.

Hardware Connections

The diagram takes the VX2000 Pro as an example.

- Via a multifunction card

Connect the Ethernet port 1 or 2 to a multifunction card, and then connect the multifunction card to an external speaker.

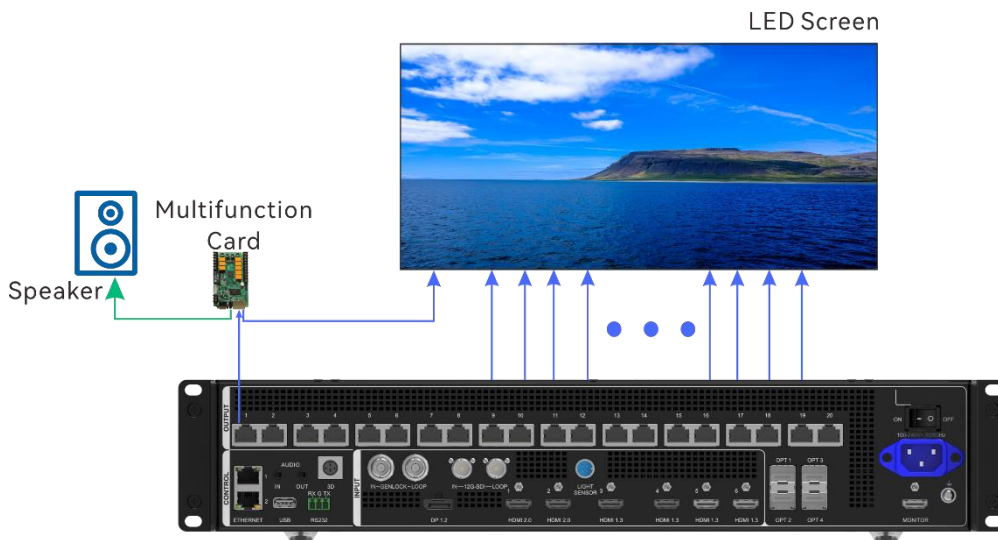

- Via the audio output connector
Connect the audio output connector to an external speaker.

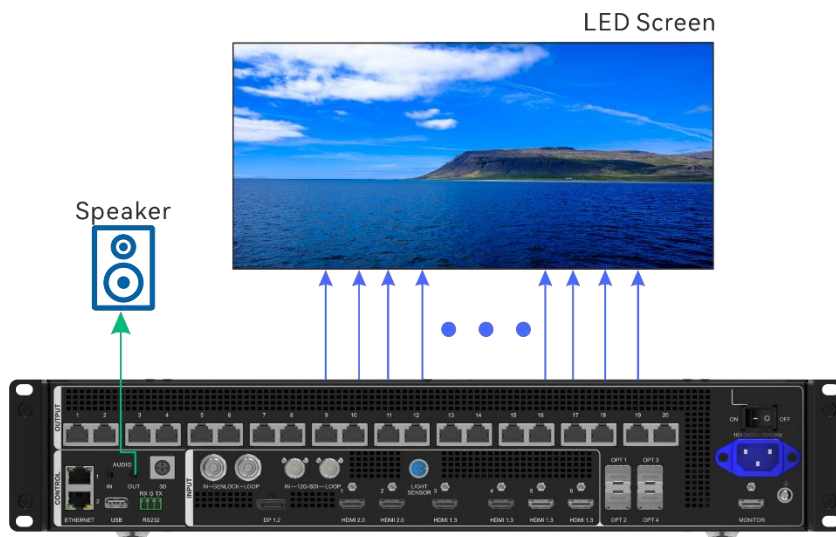

Screen Example

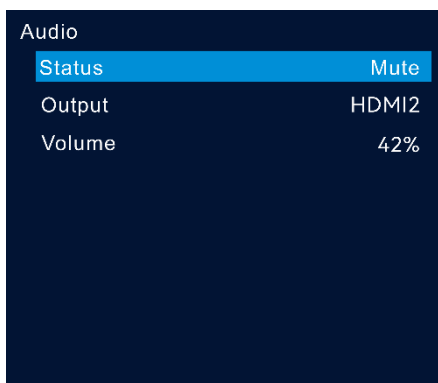

4.8.3.1 Set Audio Status

Turn on or turn off the audio, and adjust the output and volume settings as needed.

Screen Example

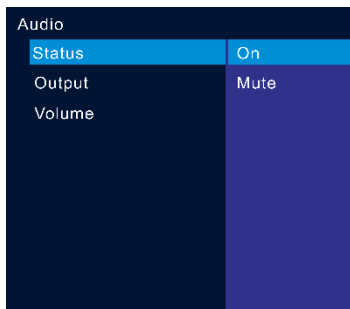

Operating Procedure

- Step 1 On the main menu screen, go to **Advanced Settings > Audio** to enter the audio settings screen.
- Step 2 Rotate the knob to select **Status** and press the knob to confirm.
- Step 3 Rotate the knob to select **On** or **Mute** to turn on or turn off the audio.

4.8.3.2 Select Output Audio

Set to play which audio on the external audio.

Notes

Only the VX2000 Pro supports output of the accompanied audio that comes from a DP connector.

Screen Example

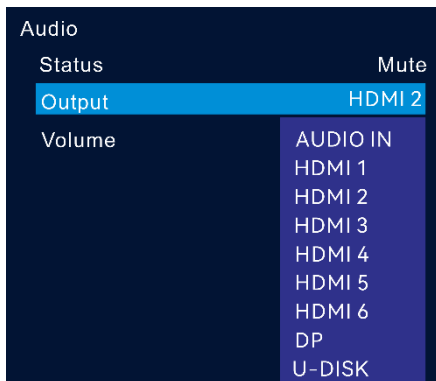

Operating Procedure

Step 1 On the main menu screen, go to **Advanced Settings > Audio > Output** and press the knob to display the output audio list.

Step 2 Select the desired output audio and press the knob to confirm.

- AUDIO IN: Output the analog audio that comes from an external audio device.
- HDMI: Output the accompanied audio that comes from an HDMI connector.
- DP: Output the accompanied audio that comes from a DP connector.
- U-DISK: Output the audio of a USB source.

4.8.3.3 Set Output Volume

Adjust the output volume.

Screen Example

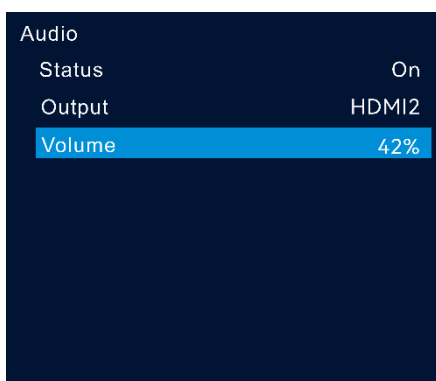

Operating Procedure

- Step 1 On the main menu screen, go to **Advanced Settings > Audio** to enter the audio settings screen.
- Step 2 Rotate the knob to select **Volume** and press the knob to confirm. Then rotate the knob again to adjust the audio volume and press the knob to confirm.

Parameter Descriptions

| Parameter | Description |
|-----------|--|
| Volume | The output volume The value ranges from 0 (silent) to 100 (loudest) and defaults to 50. |

4.8.4 Low Latency

When the input source travels from where it comes to the processing device, sending device and then the receiving card, latency exists inevitably. Turning on this function can effectively help to reduce the latency from the input to output.

Notes

To enable low latency, please make sure all Ethernet ports load the cabinets vertically and share the same Y coordinate. Free screen configuration (for example, Ethernet port 2 loads cabinets horizontally, or its Y coordinate is different from that of Ethernet port 1) will reduce the load capacity.

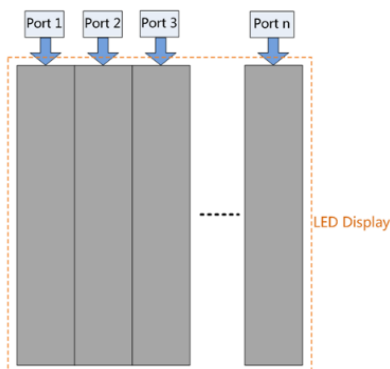

Operating Procedure

On the main menu screen, go to **Advanced Settings > Low Latency** and press the knob to confirm. Then rotate the knob again to turn on or turn off the function and press the knob to confirm.

4.8.5 3D

Directly connect a third-party 3D emitter using the device's built-in 3D connector, or connect to the EMT200 emitter via the device's Ethernet port. Then, use the compatible 3D glasses to achieve a 3D display effect.

Prerequisites

- Video source format: Side-by side, top-and-bottom or frame sequential
- When paired with the EMT200, it is recommended to use a 3D source of 60Hz to enjoy an optimal experience.

Notes

- Enabling the 3D function will halve the device output capacity.
- The 3D function and input cropping cannot be enabled at the same time.
- After enabling the 3D function on the advanced settings screen, 3D switches of all the layers will be toggled on. If you want to use a 2D layer, please toggle off the 3D switch of the desired layer on the layer settings screen.
- The 3D effect follows the layer. The output area where a 3D layer is located always displays the 3D effect.

Hardware Connections

The diagram takes the VX2000 Pro as an example.

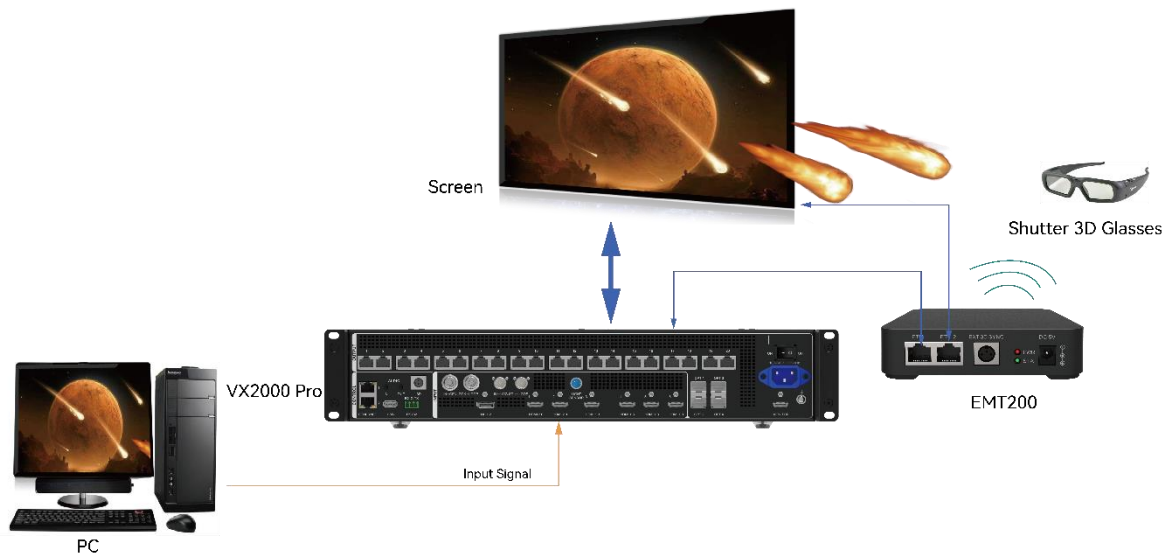

Screen Example

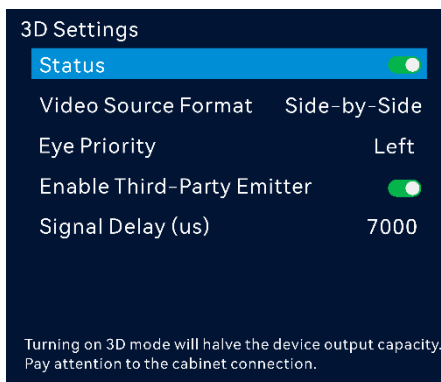

Operating Procedure

- Step 1 On the main menu screen, go to **Advanced Settings > 3D Settings > Status** to turn on the function.
- Step 2 Select the 3D format of the video source. The options include **Side-by-Side**, **Top-and-Bottom** and **Frame Sequential**.
- Step 3 Set the eye priority. The options include **Left** and **Right**.
- Step 4 (Optional) Turn on the **Enable Third-Party Emitter** switch.
- Step 5 Set the signal delay duration.

The value ranges from 0 to 20000 and defaults to 7000. (Step: 1, unit: us)

4.8.6 Working Mode

Setting device and OPT wording modes are both supported.

4.8.6.1 Device Working Mode

Three working modes are supported, including **Video Controller**, **Fiber Converter** and **ByPass**.

Screen Example

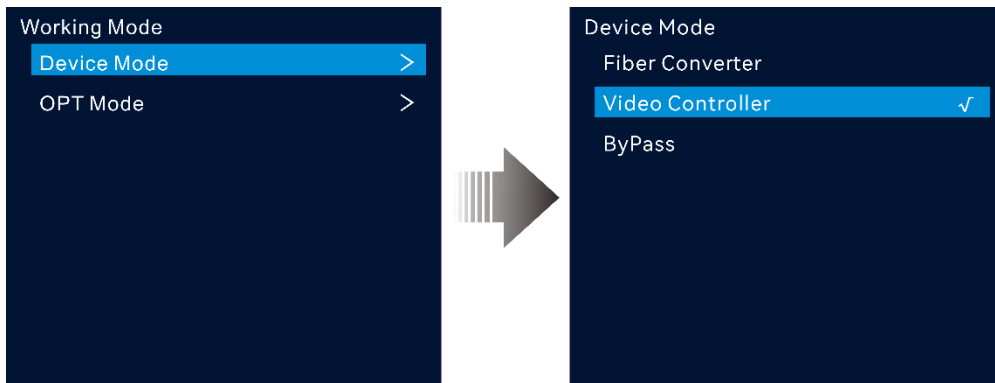

Parameter Descriptions

| Device Model | Parameter | Description |
|--------------|------------------|--|
| VX2000 Pro | Fiber Converter | <p>Optical fiber ports are used for input, and Ethernet ports are used for output.</p> <ul style="list-style-type: none"> • OPT 1~4 are used for input, and Ethernet ports are used for output. • OPT 1 and OPT 2 serve as the primary connectors. The Ethernet ports 1~10 transmit OPT 1 data, and Ethernet ports 11~20 transmit OPT 2 data. • OPT 3 and OPT 4 serve as the backup connectors. |
| VX2000 Pro | Video Controller | <ul style="list-style-type: none"> • OPT 1 and OPT 2 can be used as an input or output connector depending on the connected devices. • OPT 1 and OPT 2 send the output on Ethernet ports 1~10 and 11~20 respectively. OPT 3 and OPT 4 copy or back up the output on Ethernet ports 1~10 and 11~20 respectively. |
| VX2000 Pro | ByPass | Under this mode, the device works as an independent controller with no support for video processing functions. |

4.8.6.2 OPT Mode

Supports settings of both the OPT working mode and loop mode.

Screen Example

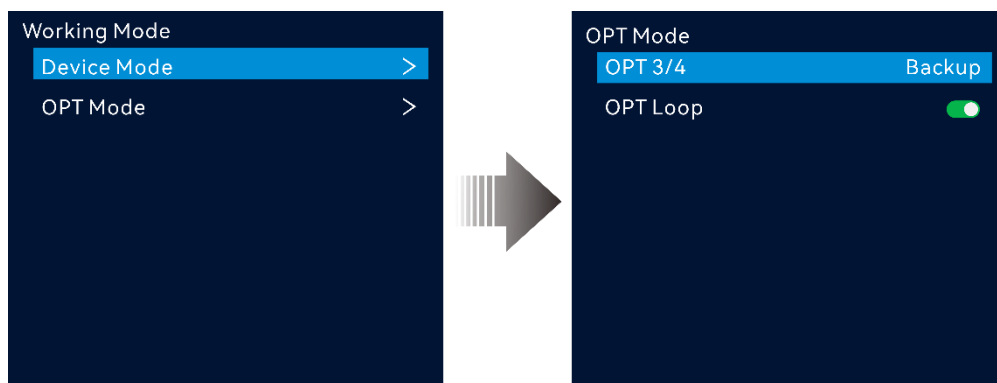

Hardware Connections

The diagram takes the VX2000 Pro as an example.

Figure 4-13 Copy mode

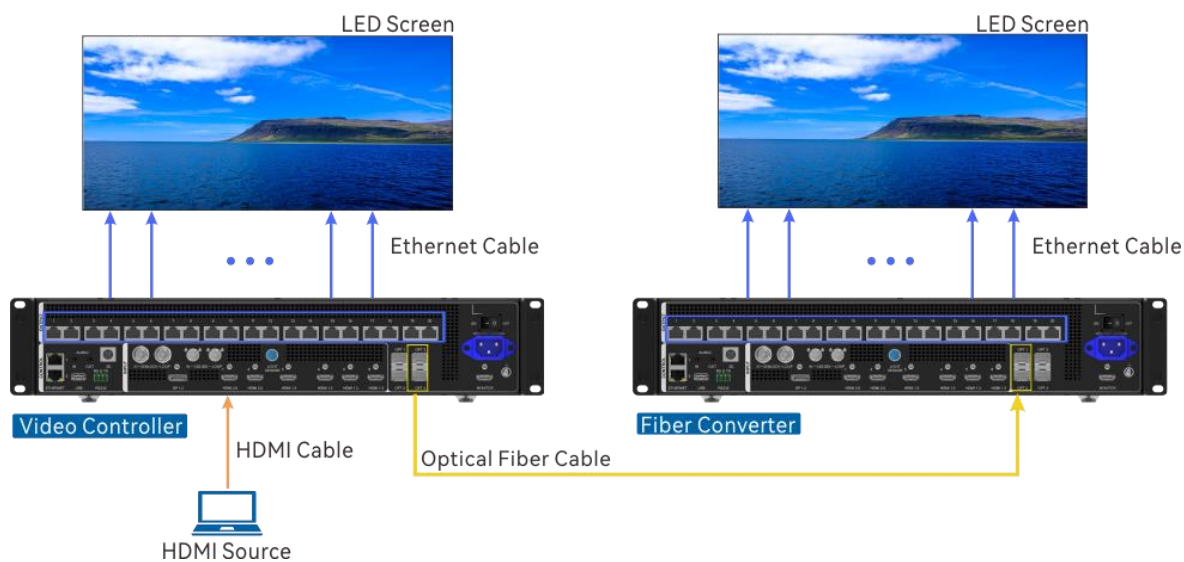

Figure 4-14 Backup between Ethernet and OPT ports

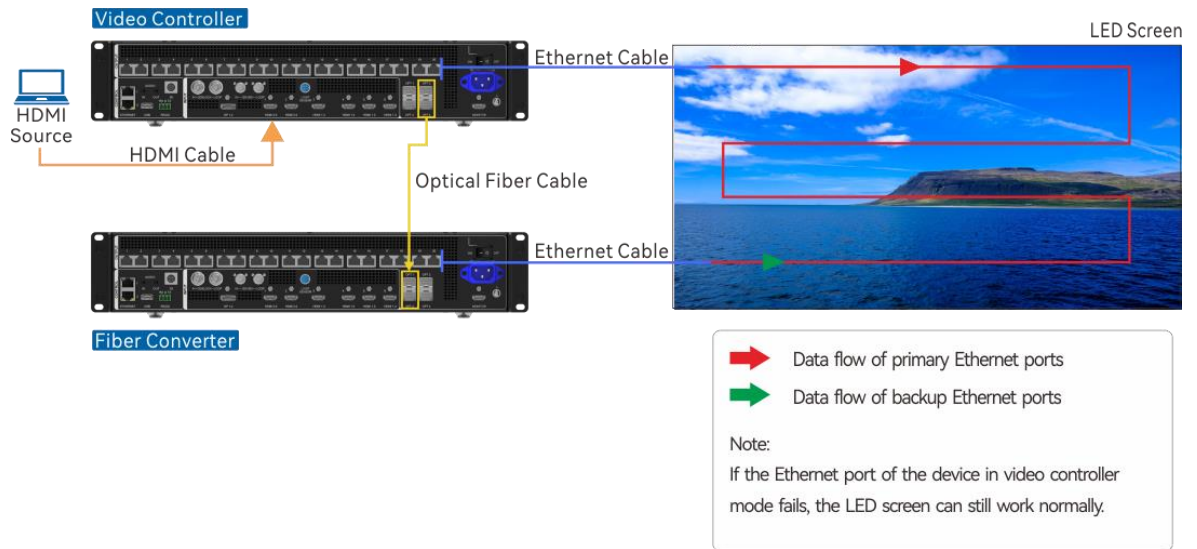
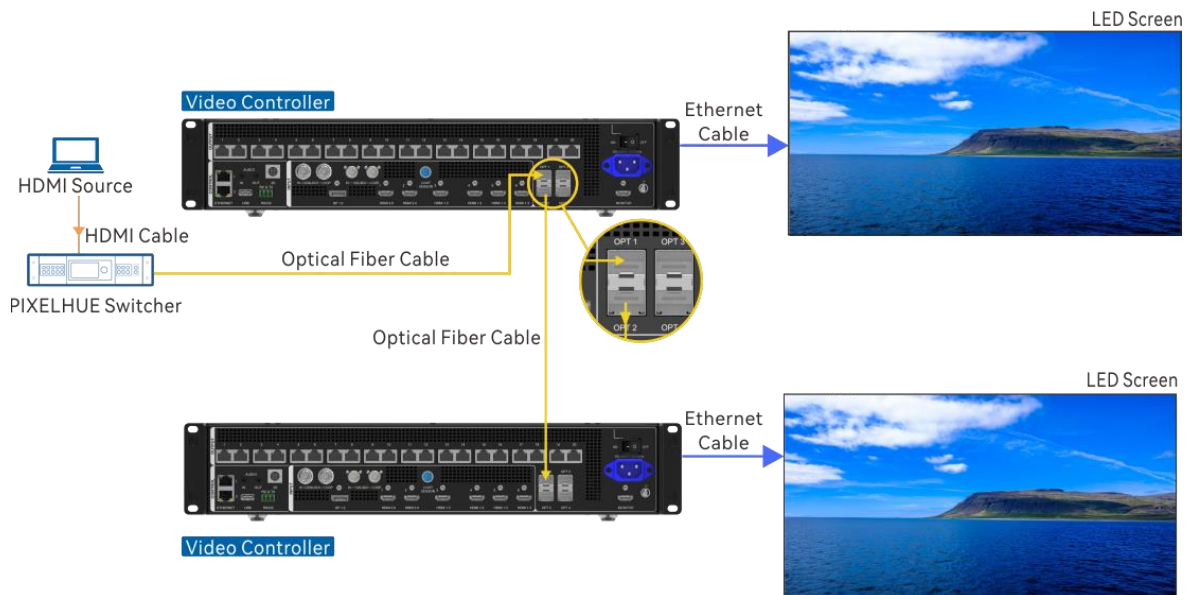



Figure 4-15 OPT loop mode



Parameter Descriptions



| Device Model | Parameter | Description |
|--------------|-----------|--|
| VX2000 Pro | OPT 3/4 | <ul style="list-style-type: none"> Copy: OPT 3 copies the output on Ethernet ports 1~10, and OPT 4 copies the output on Ethernet ports 11~20. Backup: OPT 3 backs up the output on Ethernet ports 1~10, and OPT 4 backs up the output on Ethernet ports 11~20. |
| VX2000 Pro | OPT Loop | Loop out the video signal accessed by OPT 1 via OPT 2 for device mosaic. |

| Device Model | Parameter | Description |
|--------------|-----------|---|
| | | <ul style="list-style-type: none"> : Enable the loop mode. : Disable the loop mode. |

4.8.7 HDCP Status

High-bandwidth Digital Content Protection (HDCP) is a form of digital copy protection to prevent copying of digital audio and video content as it travels across connections. When the accessed input source is an HDCP-encrypted one, you need to turn on this function to enable the device to transmit and process the source.

Parameter Descriptions

| Parameter | Description |
|-------------|---|
| HDCP Status | Turn on or turn off the function. <ul style="list-style-type: none"> : On : Off |

4.8.8 Monitor Settings

Real-time display of the output image via the monitor connected is supported. You can monitor whether the output is normal and adjust the display ratio of the monitoring image on the monitor to avoid image distortion.

Notes

The output resolution of the monitor connector is fixed at 1920×1080@60Hz.

Parameter Descriptions

| Parameter | Description |
|------------------|---|
| Monitor Settings | The options include Keep Ratio and Full Screen (default). <ul style="list-style-type: none"> Keep Ratio: Keep the ratio of the original output image to display. Full Screen: Display the output image in full screen. <div style="background-color: #f0f0f0; padding: 5px; margin-top: 10px;">  Note </div> |

| Parameter | Description |
|-----------|--|
| | When Keep Ratio is selected, the blank area that the output image cannot cover the entire monitor screen will be automatically filled with solid black. |

4.9 System Settings

4.9.1 Fn

This function allows you to set a shortcut button for an assigned function. By using the Fn button, you can quickly navigate to the target menu screen and never need to access a specified menu item by entering the menus level by level.

Screen Example

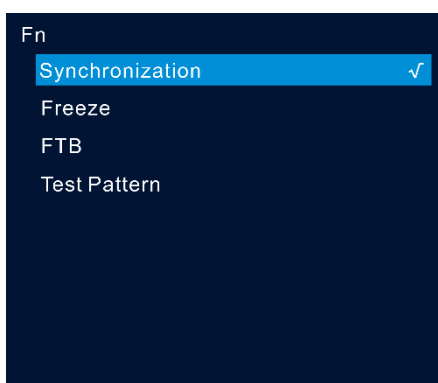

Operating Procedure

- Step 1 On the main menu screen, go to **System Settings > Fn** press the knob to enter the Fn button settings screen.
- Step 2 Rotate the knob to select the desired function and press the knob to confirm.

4.9.2 Return to Home

Operating Procedure

- Step 1 On the main menu screen, go to **System Settings > Return to Home** and press the knob to confirm.

Step 2 Rotate the knob to select the desired time value and press the knob to confirm.

Parameter Descriptions

| Parameter | Description |
|----------------|---|
| Return to Home | You can set the period when the system stays at the current screen before returning to the homepage automatically when there is no operation performed. The value ranges from 60s to 3600s |

4.9.3 Diagnostics

The diagnostics function helps you to diagnose the system and troubleshoot the malfunctioned device components. When the device fails, you can run the diagnostics function to test the device. You can send your test to our technical support staff for problem locating and processing. For daily maintenance, you can run the diagnostics function to do the routine health check for the system.

Notes

Running diagnostics will transiently disrupt the output, and the output will resume after the diagnostics are completed.

Operating Procedure

Step 1 On the main menu screen, go to **System Settings > Diagnostics** and press the knob to enter the diagnostics screen.

Step 2 Rotate the knob to select **Run Diagnostics** and press the knob to confirm,

Step 3 In the popup dialog, rotate the knob and select **Yes** and press the knob to confirm.

4.9.4 Export Logs

Export the device logs to a USB drive to quickly identify issues.

Prerequisites

Before exporting logs, you have inserted a USB drive into the USB port on the device.

Operating Procedure

- Step 1 On the main menu screen, go to **System Settings > Log Export** to enter the log exporting screen.
- Step 2 Rotate the knob to select **Apply** and press the knob to confirm. The log file will be exported to the root directory of the USB drive.

4.9.5 Update Device

Import the update file saved in a USB drive to the device for quick update.

Notes

During the update process, power-off and all operations are NOT allowed.

Operating Procedure

- Step 1 On the main menu screen, go to **System Settings > Update** to enter the device update screen.
- Step 2 Rotate the knob to select the update file and press the knob to confirm.
- Step 3 In the popup dialog box, rotate the knob to select **OK** and press the knob to confirm. Then wait for the device to automatically complete the update.

4.9.6 Cascading ID

Set the device cascading ID which is the unique identification when the device is in a cascading link.

Notes

- The cascading ID defaults to **1** and can be changed manually. You need to set an ID for each cascading device in order.

- After you set IDs successfully, connect devices using Ethernet cables based on the set ID.

Parameters Description

| Parameter | Description |
|--------------|---|
| Cascading ID | When multiple devices are cascaded, you need to set a virtual ID for each device, ensuring that the devices displayed in NovaLCT match with actual devices. |

4.9.7 About Us

Under this menu item, you can view the firmware version, device SN, official website and email address. On our official website, you can check the latest device information and the updates for this device. You can also send your feedback or suggestion to us for improvements via the supplied email address.

Screen Example



4.10 Factory Reset

Factory reset function allows you to reset all the parameter settings of the device to factory defaults after the device update or when you think the parameters are improperly set.

Screen Example

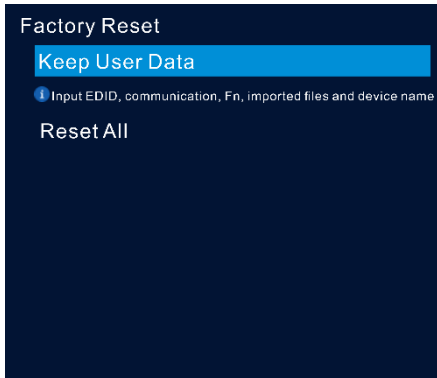

Parameter Descriptions

| Parameter | Description |
|----------------|---|
| Keep User Data | Reset the parameter settings to factory defaults, except for the Input EDID, communication, Fn, imported files and device name. |
| Reset All | Reset all the parameter settings to factory defaults. |

4.11 Communication Settings

You can set the communication and network information to enable the device to communicate with the control PC smoothly.

Screen Example

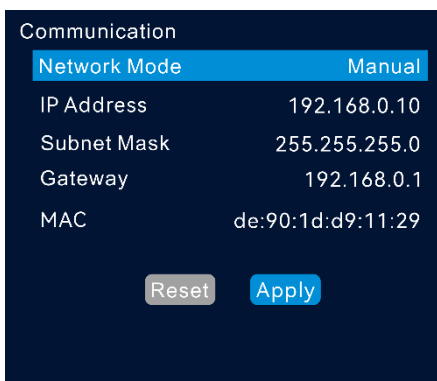

Operating Procedure

Step 1 On the main menu screen, rotate the knob to select **Communication** and press the knob to enter the communication settings screen.

Step 2 Select **Network Mode** and press the knob to confirm.

The options include **Manual** and **Automatic**.

- Manual: Set the device IP address, subnet mask and gateway manually.
- Automatic: The system automatically assigns an IP address for the device. When the device and control PC are connected to the same router or switch, set this option to **Automatic**.

Step 3 When the **Manual** option is selected, you must manually set the device IP address, subnet mask and gateway.

Step 4 Rotate the knob to select **Apply** to make the settings take effect; otherwise, select Reset to reset the settings to defaults.

4.12 Language

The language options include English and Simplified Chinese. You can switch to your preferred language.

5 Software Control

5.1 Software Installation and Connection

5.1.1 Software Installation

Prerequisites

- The software package is obtained.
- A computer meeting the following requirements is prepared:
 - Operating system: Windows 10 (64-bit) or later
 - CPU: Intel® Core™ i5 or later
 - RAM: 8 GB or greater

Installation Method

Run the .exe file and follow the setup wizard to complete the installation. If a firewall prompt appears, choose to allow the installation.

Installation Result

After a successful installation, the Unico software icon  is displayed on the desktop. Double-click this icon to open the Unico software.

5.1.2 Software Connection

The Unico software is installed on the control computer. The control computer can connect to the device in the following two ways:

- Via Ethernet cable

Connect the device and the control PC directly via Ethernet cable and set a static IP address for the device to let it and the control PC be on the same network segment.

- Via LAN

Connect the device and the control PC to the same LAN to ensure that both of them are on the same network segment.

5.2 Project Management

Create, edit and delete projects, and view project details. The project file (.uprj) can be exported by a device, and then imported into other devices of the same model, so as to quickly apply the device parameters and resource files in the project file.

5.2.1 Create New Projects

All the online devices on the same LAN will be automatically added to a default project. Users can create a new project and remove the desired device from the default project to the new one.

Step 1 Select **Projects** on the left side of the interface to show the project list.

Figure 5-1 Project list

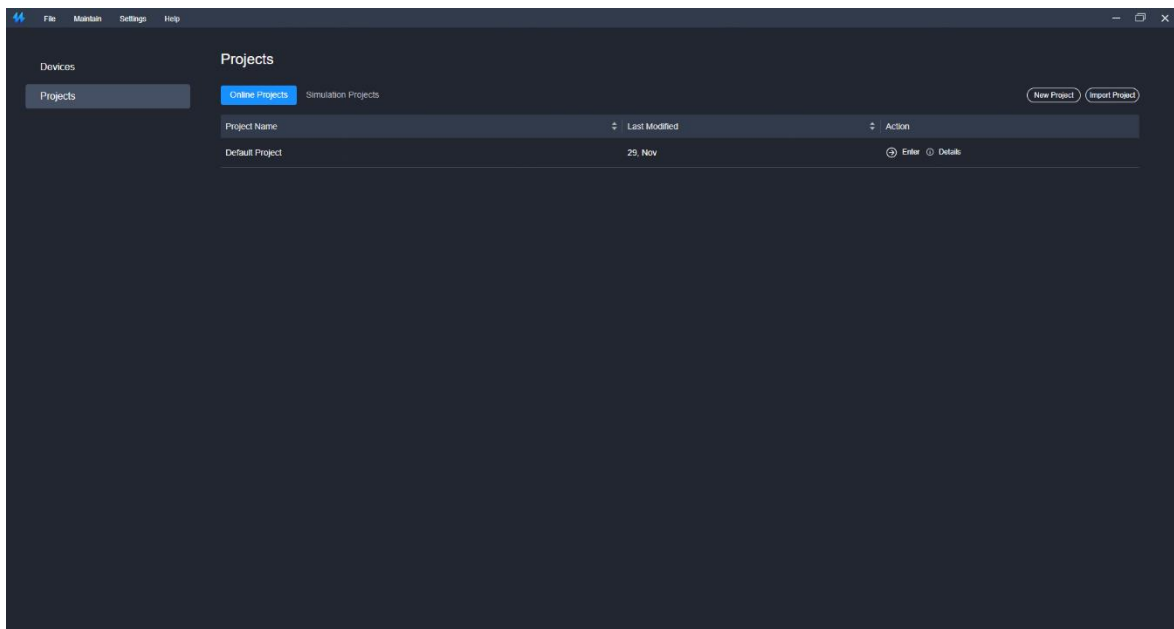

Step 2 Click **New Project** on the **Online Projects** tab interface.

Figure 5-2 Create online projects (VX2000 Pro)

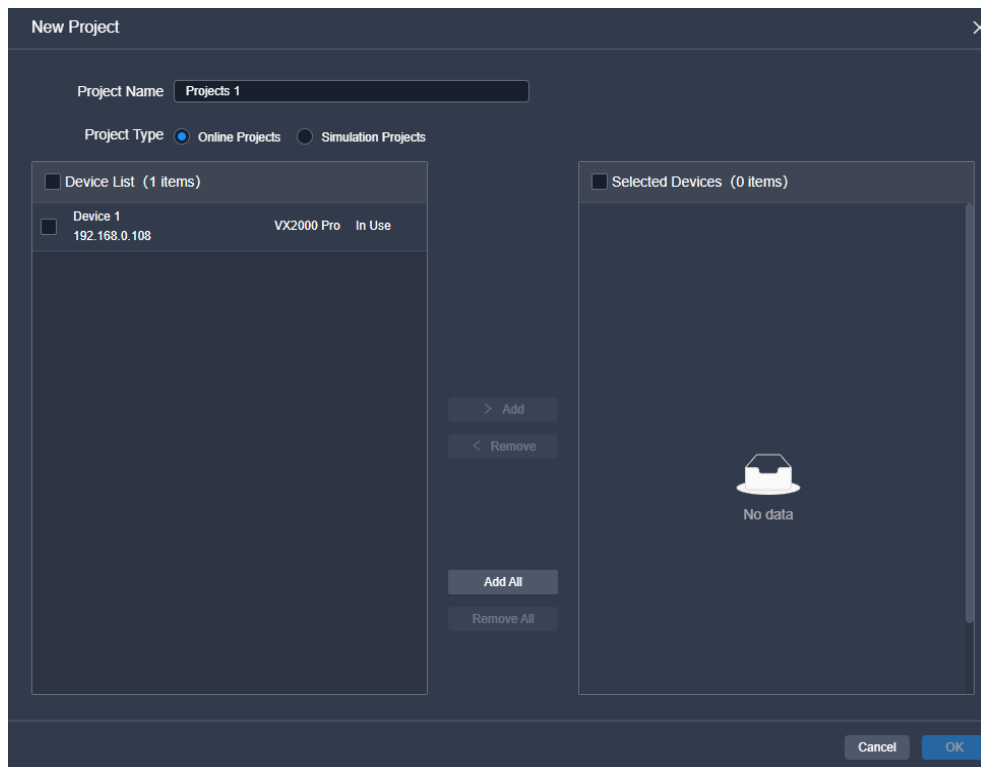

Step 3 Name the project.

Step 4 Select the devices that you want to include in the project, and click **Add**.

 **Note**

A device can be added to one project only.

Related operations are as follows:

- Remove: Withdraw the selected devices in **Selected Devices** list to **Device List**.
- Add All: Add all the devices in **Device List** to **Selected Devices** list.
- Remove All: Withdraw all the devices in **Selected Devices** list to **Device List**.

Step 5 After the settings, click **OK**.

After a project is successfully created, you will enter the device configuration interface.

 **Note**

In the project list area, you can perform the following project-related operations:

- Rename project: Hover the mouse over the desired project and click  that appears on the right side of the project name.
- Enter project: Click **Enter** in the **Action** column.
- Edit project: Click **Edit** in the **Action** column.

- Delete project: Click **Delete** in the **Action** column.
- View project details: Click **Details** in the **Action** column.

5.2.2 Import Projects

Import the local project files (.uprj) to the device. Please note that the device models must match with the models in the project file.

- Step 1 Select **Projects** on the left side of the interface to show the project list.
- Step 2 Click **Import Project** or go to **File > Import**.
- Step 3 In the dialog box that appears, select a project file (.uprj) and click **OK**.
- Step 4 In the displayed **Import Project File** window, select **Online Projects**.

Figure 5-3 Import project files

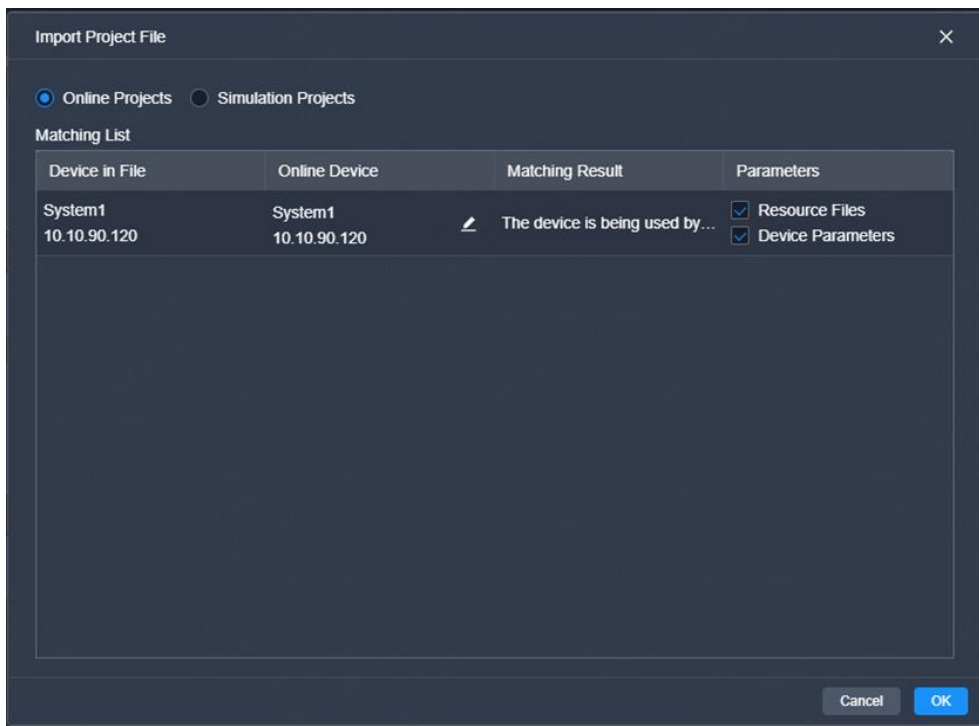

- Step 5 After successful device matching, select the data to be imported and click **OK**.

The software matches the SN, name, IP address, model, and firmware version from the file with the online device.

Click and select other online devices from the drop-down menu.

5.2.3 Export Projects

Export the device project files to your local computer.

- Step 1 Select **Projects** on the left side of the interface to show the project list.
- Step 2 Select the **Online Projects** tab, double-click the project name or click **Enter** in the **Action** column to enter the device configuration interface.
- Step 3 In the menu bar, select **File > Export**.
- Step 4 In the displayed dialog box, select the desired data.

Figure 5-4 Export project files

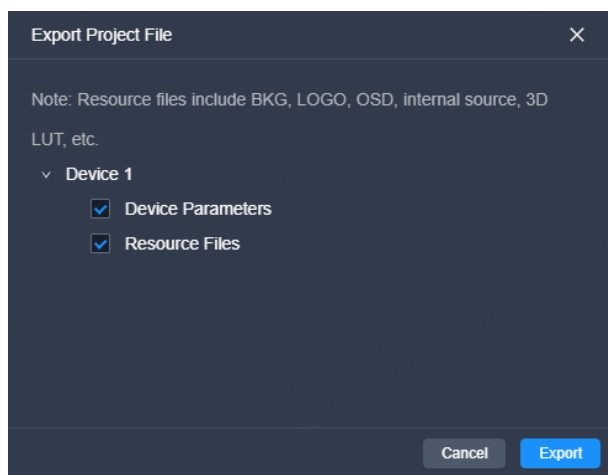

- Step 5 Click **Export**.
- Step 6 In the displayed dialog box, select a file path and click **Save**.

5.3 Device Management

5.3.1 Enter Device Configuration Page

5.3.1.1 Online Devices

- Step 1 Select **Devices** on the left side of the interface to show the device list.

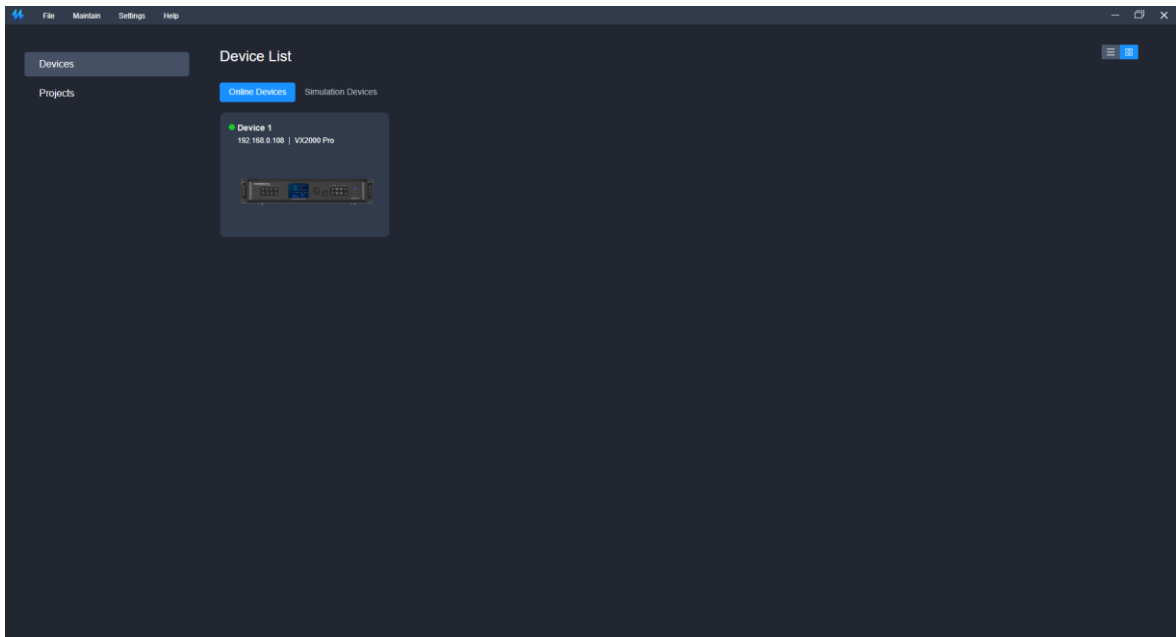

Figure 5-5 Online device list (VX2000 Pro)





Step 2 (Optional) Switch the display style of the device list as desired.

- : Graphical view
 - View the device name, IP address and model.
 - Double clicking the device front panel image allows you to access the device configuration interface.



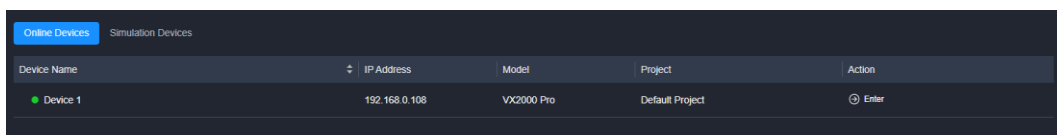

- : List view
 - View the device name, IP address, model, and the project the device belongs to.
 - In the **Action** column, you can access the device configuration interface.
 - Place the mouse over the device information and click  that appears on the right side of the device name to change the device name.



| Device Name | IP Address | Model | Project | Action |
|-------------|---------------|------------|-----------------|---|
| Device 1 | 192.168.0.108 | VX2000 Pro | Default Project |  Enter |

Step 3 Perform either of the following actions to enter the device configuration page.

- In the graphic view mode () , double click the image of the device front panel.
- In the list view mode () , click **Enter** in the **Action** column.

5.3.2 Configure Device Properties

Select the device on the left side of the device configuration interface, and then configure the device-related properties on the right pane.

Figure 5-6 Device properties (VX2000 Pro)

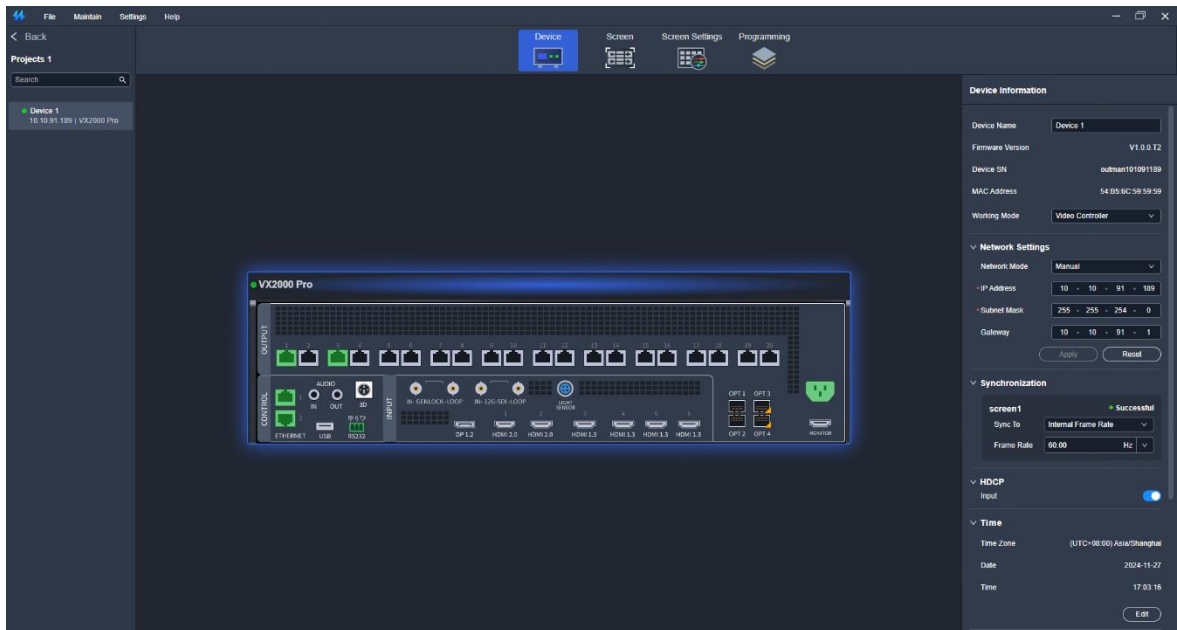

5.3.2.1 Rename Device

Change the device name.

Prerequisites

None

Notes

None

Interface Example

| | |
|------------------|-------------------|
| Device Name | Device 1 |
| Firmware Version | V1.0.0 |
| Device SN | outman101091189 |
| MAC Address | 54:B5:6C:59:59:59 |
| Working Mode | Video Controller |

Description

Enter a name for the device in the text box next to **Device Name**.



In the device list on the left side of the interface, you can also right click the device name and select **Rename** from the context menu to change the device name as well.

5.3.2.2 Switch Working Mode

Switch the device working mode.

Prerequisites

None

Notes

Set the device working mode according to the on-site application and screen connections.

Interface Example

| | |
|------------------|-------------------|
| Device Name | Device 1 |
| Firmware Version | V1.0.0 |
| Device SN | outman101091189 |
| MAC Address | 54:B5:6C:59:59:59 |
| Working Mode | Video Controller |

Description

Select **Video Controller**, **Fiber Converter** or **ByPass** from the drop-down list.

5.3.2.3 Configure IP Address

Manually set a static IP address for the device or let the device to automatically obtain an IP address.

Prerequisites

None

Notes

None

Interface Example

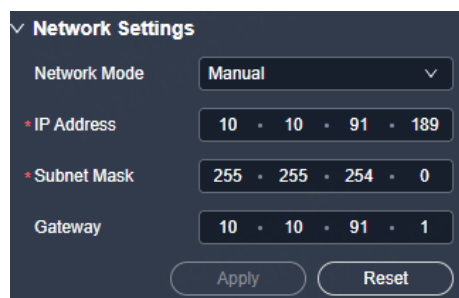

The screenshot shows a 'Network Settings' panel with a dark background. At the top, 'Network Mode' is set to 'Manual' in a dropdown menu. Below it, the IP Address is '10 · 10 · 91 · 189', the Subnet Mask is '255 · 255 · 254 · 0', and the Gateway is '10 · 10 · 91 · 1'. At the bottom, there are 'Apply' and 'Reset' buttons.

Description

Configure the following parameters and click **Apply** to make the settings take effect.

| Parameter | Description |
|--------------|--|
| Network Mode | Select the IP configuration method. <ul style="list-style-type: none">• Manual: Manually set a static IP address for the device.• DHCP: The device automatically obtains an IP address. |
| IP Address | The device IP address |
| Subnet Mask | The subnet mask of the IP address |

| Parameter | Description |
|-----------|---------------------|
| Gateway | The default gateway |

5.3.2.4 Configure Sync Source

Select a sync signal to synchronize all the cascaded device units or synchronize the primary and backup devices to display the output images of all the units in sync.

Prerequisites

Before enabling the Genlock sync function, make sure the sync signal has been connected to the Genlock connector of the device.

Note

None

Interface Example

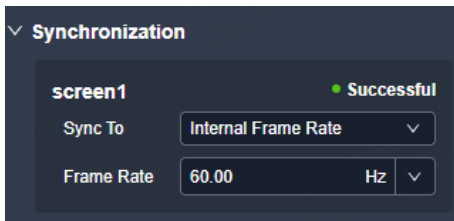

Description

| Parameter | Description |
|------------|---|
| Sync To | <p>Select a sync source.</p> <ul style="list-style-type: none"> • Internal Frame Rate: The frame rate of the output image • DP/HDMI X/SDI: Sync with the frame rate of the selected input source. "X" represents the input source number and its format may vary depending on the actual setup. • Genlock: Sync with the frame rate of the Genlock signal. <p>When the function is enabled, the frame rate of the sync source will be displayed.</p> |
| Frame Rate | When you select Internal Frame Rate , you can manually set the output frame |

| Parameter | Description |
|-----------|----------------------------------|
| | rate. The default value is 60Hz. |

5.3.2.5 Configure HDCP

High-bandwidth Digital Content Protection (HDCP) is a form of digital copy protection to prevent copying of digital audio and video content as it travels across connections. When the accessed input source is an HDCP-encrypted one, you need to turn on this function to enable the device to transmit and process the source.

Prerequisites

None



Notes

None

Interface Example



Description

| Parameter | Description |
|-----------|--|
| HDCP | Turn on or turn off the function. <ul style="list-style-type: none">• : On• : Off |

5.3.2.6 Configure Date and Time

Configure the time zone, date and time of the device.

Prerequisites

None

Notes

None

Interface Example

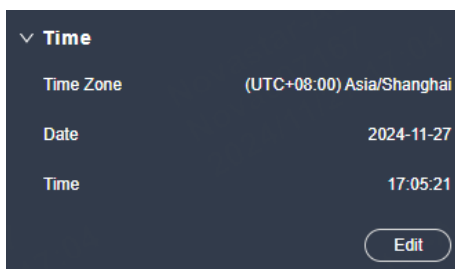

Description

Click **Edit** and the parameters become editable. Set the time zone, date and time respectively, and then click **Apply**.

5.3.2.7 Configure Input Source Backup

Establish a backup relation for two input sources.

Prerequisites

None

Notes



- The backup relation can only be established if the input connectors have identical capacities.
- Once the function is enabled, the switching of the connector capacity is not supported.
- In the **Manual** mode, use the designated source only regardless of signal availability. In the **Auto** mode, adhere to the following principles when the primary source transitions from no signal to signal presence:

- If **Primary Source Preferred** is selected, automatically switch to the primary source.
- If **Primary Source Preferred** is not selected, continue using the backup source.

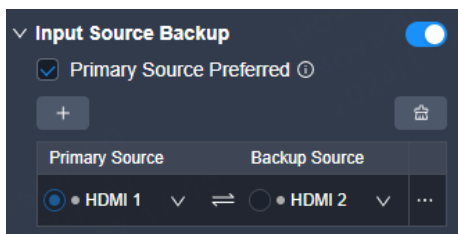
Interface Example



Description

- Step 1 Set the **Input Source Backup** switch to .
- Step 2 Select or deselect **Primary Source Preferred**.
- Step 3 Click .
- Step 4 Select a primary source and a backup source respectively from two drop-down lists to establish a hot backup pair.

The green dot  indicates the source is accessed normally and ready for use.

- To delete a hot backup pair, click  next to the pair and click **Delete**.
- To delete all hot backup pairs, click .

- Step 5 Click  on the right and set **Mode** to either **Auto** or **Manual**.

If **Manual** is selected, you will also need to choose the desired source.

5.3.2.8 Reset to Factory Settings

Reset the device data and settings to factory default values.

Prerequisites

None

Notes

- Please do this with great caution.
- The reset action does not affect the device firmware version.
- Power-off is not allowed during the reset process.
- The device will restart automatically after the reset is completed.

Interface Example

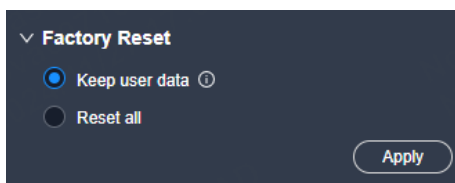

Description

Select **Keep user data** or **Reset all**, and then click **Apply**.

- Keep user data

Retain the device IP address, input connector EDID, gallery files, language settings, device name and belonged project.

- Reset all

Retain the device IP address and belonged project.

5.3.2.9 Restart Device

Restart the device.

Prerequisites

None

Notes

None

Interface Example

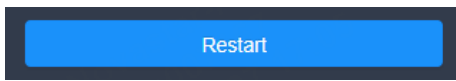

Description

Click **Restart**, and then click **Yes** in the displayed dialog box.

5.3.3 Configure Input Properties

Click the target input connector on the graphical device rear panel, and then set the input-related properties in the property area on the right pane.

Figure 5-7 Input properties (VX2000 Pro)

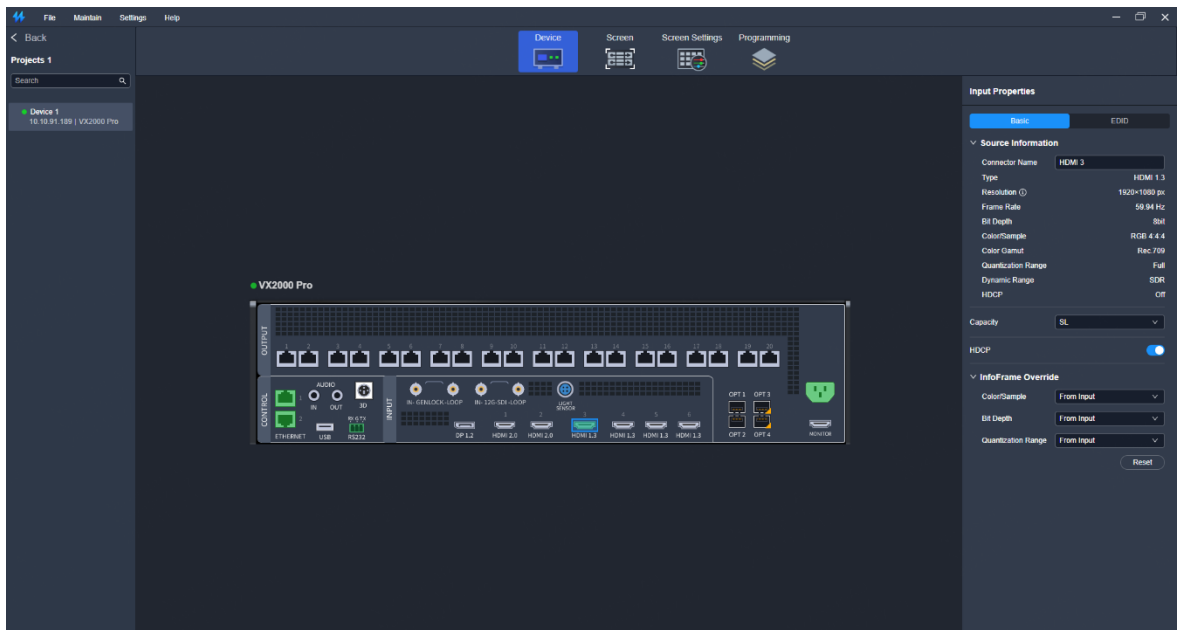

5.3.3.1 View Input Source Info

View the basic properties of the input connector and change the input connector name.

Prerequisites

A fine signal is connected to the input connector.

Notes

None

Interface Example

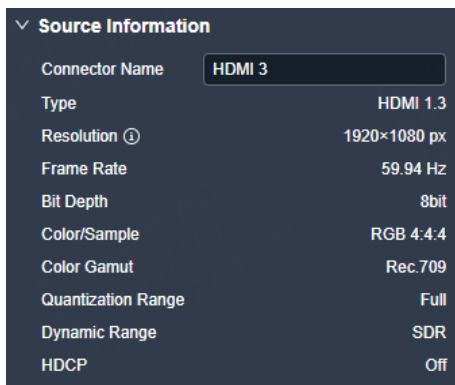

Description

On the **Basic** tab interface, change the connector name as required.

5.3.3.2 Set OPT Ports

Set the OPT working mode and loop mode.

Prerequisites

The device working mode is set to **Video Controller**.



Notes

None

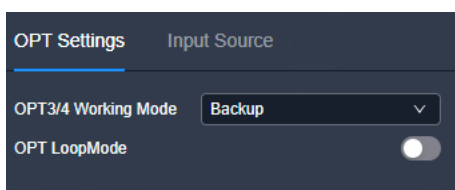
Interface Example



Description

| Device Model | Parameter | Description |
|--------------|----------------------|---|
| VX2000 Pro | OPT 3/4 Working Mode | <p>OPT 3 and OPT 4 working modes</p> <p>Config method: Select Copy or Backup from the drop-down list.</p> <ul style="list-style-type: none"> • Copy: OPT 3 and OPT 4 copy the output on Ethernet port 1~10 and 11~20 respectively. <p>After you complete the settings, the OPT ports on the graphical device panel will be highlighted.</p> <ul style="list-style-type: none"> • Backup: OPT 3 and OPT 4 back up the output on Ethernet port 1~10 and 11~20 respectively. <p>After you complete the settings, the backup icons will be displayed at the bottom right corner of the OPT ports on the graphical device panel.</p> |
| VX2000 Pro | OPT LOOP Mode | <p>Turn on or turn off the function.</p> <ul style="list-style-type: none"> • On:  <p>After this function is enabled, the video signal accessed by OPT 1 will be looped out via OPT 2.</p> <ul style="list-style-type: none"> • Off:  |

5.3.3.3 View OPT Source Info

View the basic properties of the OPT source and change the OPT port name.

Prerequisites

- The device working mode is set to **Video Controller**.
- OPT 1 and OPT 2 is connected to the OPT ports on the front-end video processor via optical fiber cables. Additionally, a fine signal is connected to the front-end device.

Notes

Each OPT support the transmission of 1x DL or 2x SL sources.

Interface Example

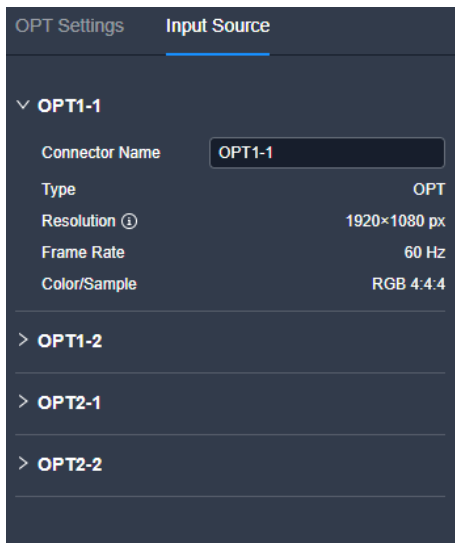

Description

On the **Input Source** tab interface, change the connector name as required.

5.3.3.4 Set Input Connector Capacity

Switch the input connector capacity as desired.

Prerequisites

Notes

Interface Example

When a connector is configured for hot backup, you can no longer switch its capacity.

Interface Example



Description

| Parameter | Description |
|-----------|--|
| Capacity | Select the desired connector capacity from the drop-down list. <ul style="list-style-type: none"> • 4K: 4K×2K • DL: 4K×1K • SL: 2K×1K |

5.3.3.5 Configure InfoFrame Override Parameters

Configure the InfoFrame override parameters of the input source, so that the device can use it when doing some calculations. This action does not change the parameter values that come with the input source.

Prerequisites

None

Notes

None

Interface Example

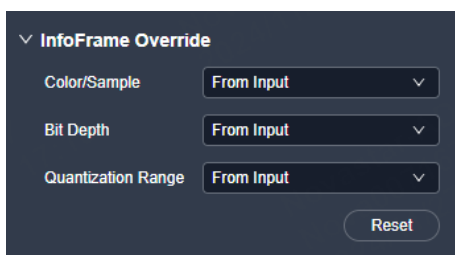

Description

On the **Basic** tab interface, configure the following parameters.

| Parameter | Description |
|--------------|----------------------------------|
| Color/Sample | The sampling format of the input |

| Parameter | Description |
|--------------------|---|
| Bit Depth | The bit depth of the input, i.e., the binary digits to represent a single color |
| Quantization Range | The quantization range of the input |

Select **From Input** and the device will read the attribute values that come with the input source.

5.3.3.6 Configure EDID

Configure the resolution and frame rate of the input. You can select the standard resolution provided by the device, customize a resolution, or set the advanced parameters.

Prerequisites

- SDI does not support this function.
- The front-end device outputs the video source from the graphics card.

Notes

It is recommended the advanced settings be carried out by the trained personnel only.

Interface Example

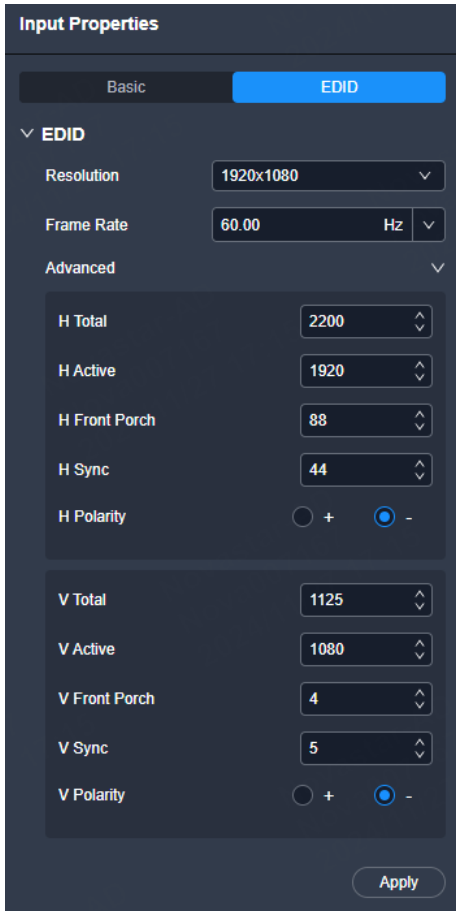

Description

On the **EDID** tab interface, configure the following parameters and click **Apply** after the settings.

| Parameter | Sub-Parameter | Description |
|------------|---------------|--|
| Resolution | - | The number of horizontal pixels and vertical pixels of the image Config method: <ul style="list-style-type: none"> • Select the desired resolution from the drop-down list. • Select Custom from the drop-down list, and then set the width and height values respectively. |
| Frame Rate | - | The image frames every second (unit: Hz) Config method: Select the standard common frame rates from the drop-down options. The available frame rates may vary according to the chosen resolution. |
| Advanced | H Total | Total pixel count per line |

| Parameter | Sub-Parameter | Description |
|-----------|---------------|---|
| | H Active | The horizontal size in pixels of the active area |
| | H Front Porch | The offset between the end of the active area and the beginning of the H sync |
| | H Sync | The horizontal sync width in pixels (or between pixels) |
| | H Polarity | The polarity of the horizontal sync pulse |
| | V Total | Total pixel count per column |
| | V Active | The vertical size in pixels of the active area |
| | V Front Porch | The offset in lines between the end of the active output area and the beginning of V sync |
| | V Sync | The vertical sync width in rows (or between rows) |
| | V Polarity | The polarity of the vertical sync pulse |

5.3.3.7 Import and Export EDID

When compatibility problem occurs on an input connector, import an intact EDID file into the device; or export an EDID file from a device and provide the EDID file to other devices or input connectors to solve the compatibility issues.

Prerequisites

SDI does not support this function.

Notes

- Each input connector supports importing one EDID file only.
- Once the EDID file is imported, the input connector will recognize and apply the parameters from the file.

Interface Example

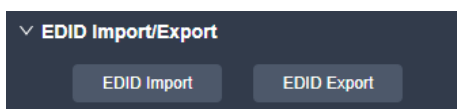

Description

- EDID Import

On the **EDID** tab interface, click **EDID Import**. In the dialog box that appears, select an EDID file and click **Open**.

- EDID Export

On the **EDID** tab interface, click **EDID Export**. In the dialog box that appears, select a path and click **Save**.

 Note

If you need to modify the content of an imported EDID file, just modify it and then re-import it to overwrite the original one.

5.3.3.8 Configure Compatibility with Mac

When the device is incompatible with the EDID of a Mac system, you may activate this feature to resolve the issue.

Prerequisites

None

Notes

None

Interface Example



Description

| Parameter | Description |
|---------------|---|
| Compatibility | Turn on or turn off the function. <ul style="list-style-type: none"> • : On |

| Parameter | Description |
|-----------|---|
| | <ul style="list-style-type: none"> <input type="radio"/> Off |

5.4 Screen Configuration

5.4.1 Configure Screen Topology

Configure the cabinet topology to complete the physical wiring connections of the cabinets on the screen.

5.4.1.1 Configure Online Cabinets

Prerequisites

The device is connected and cabinets are connected to the device.

Operating Procedure

Step 1 Select a device on the left side of the interface and then click **Screen** at the top of the page.

Figure 5-8 Screen configuration (VX2000 Pro)

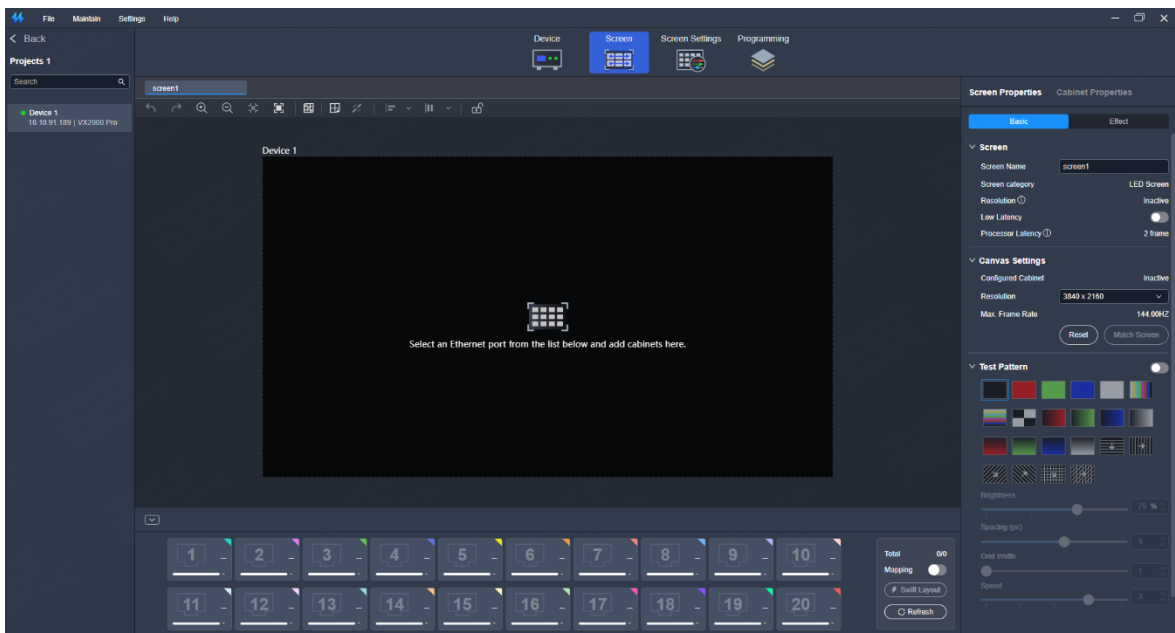

Step 2 Select an Ethernet port at the bottom and then drag and click the mouse in the topology area to add cabinets.

The cabinets will be automatically connected when you are adding them, as shown in [Figure 5-9](#). The Ethernet port's loading capacity information will be displayed, as shown in [Figure 5-10](#).

Figure 5-9 Cabinets connected automatically



Figure 5-10 Ethernet port capacity

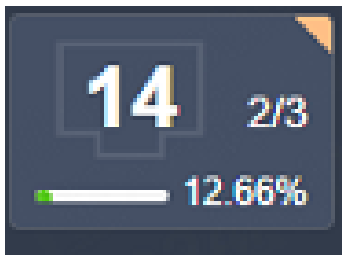

- 2/3: Indicates that there are three cabinets connected to Ethernet port 1 and 2 of which are added to the topology.
- 12.66%: Indicates these two cabinets have used 12.66% of the Ethernet port capacity.

Note

- Swift Layout: If all the cabinets loaded by the Ethernet ports have the same model, resolution, and connection topology, you can use the Swift Layout function to quickly add and connect the cabinets for all the Ethernet ports.
- Operating procedure: Click  and then drag the mouse in the topology area to add cabinets that match the actual requirements. In the properties area, select a layout and click **Done**.

Step 3 Select other Ethernet ports and continue to add cabinets until all cabinets are connected.

Step 4 For cabinets that have the same size and consecutive serial numbers, if you want to change the cabinet connection topology, select the cabinets and then select a quick topology under **Quick topo** in the properties area, as shown in [Figure 5-11](#). For other cabinets, skip this step.

Figure 5-11 Quick topology



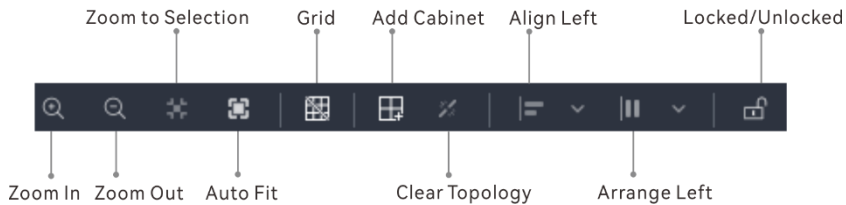

Step 5 Do any of the following to arrange and align the cabinets and cabinet groups to let the cabinet positions meet the display requirements.

- Use the function buttons.

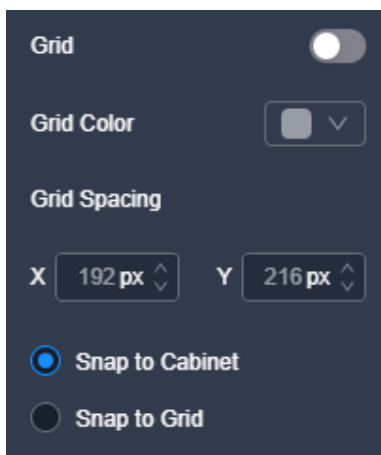

- Zoom to Selection: The selected element is zoomed and displayed in the center of the canvas.
- Auto Fit: The canvas size is automatically adjusted to fit the topology area size.
- Click  to show its drop-down menu shown below. The menu can be used to set the canvas grid.



Grid: When toggled on () , a grid is displayed on the canvas. If you do not need to display the grid, set the switch to .

Grid Color: Set the grid color.

Grid Spacing: Set the spacing of horizontal and vertical lines of the grid. The spacing is set to the resolution of the first cabinet by default.

Snap to Cabinet: When positioning a cabinet near another one, the cabinet being moved will automatically align and snap to the edge of the adjacent cabinet, effectively eliminating gaps.

Snap to Grid: The cabinet will be snapped to the grid.

- **Add Cabinet:** Add online cabinets or cabinets in the cabinet library.
- **Use the right-click function menu**
 - **Select String:** Select all the cabinets on the connection line of the current cabinet.
 - **Change Model:** Change the model of the current cabinet.
 - **Select Same Cabinets:** Select the cabinets of the same model of the current cabinet.
 - **Blackout:** Blackout the output image displayed on the current cabinet.
 - **Freeze:** Freeze the output image displayed on the current cabinet.
 - **Swap:** Swap the positions of the two selected cabinets.
 - **Group:** Select the desired cabinets and right click on them. Click **Group** in the context menu, and then the selected cabinets will be grouped for batch control. To set the group name and color, please select the group and set them in the properties area. You can also use the keyboard shortcuts **Ctrl+G** to perform the grouping operation.
 - **Ungroup:** Ungroup the cabinets. You can also use the keyboard shortcuts **Ctrl+Shift+G** to perform this action.
 - **Add to:** Add the selected cabinets to a group.
 - **Clear Topology:** Clear the current cabinet topology.
 - **Delete:** Delete the selected cabinet. You can also use the keyboard shortcuts **Del** to perform this action.
- **Right click on the canvas edge and use the function menu**

| | |
|------------------------------|--------|
| Zoom to Selection | Ctrl+D |
| Fit Screen | Ctrl+F |
| Zoom 1:1 | Ctrl+0 |
| Display Grid | |
| Snap to Grid | |
| Snap to Cabinet | ✓ |
| Display Topology | ✓ |
| Display Status | ✓ |
| Display Cabinet Color | ✓ |
| Display Group Name | ✓ |
| Display Overlapping Cabinets | |

- Zoom to Selection: The selected element is zoomed and displayed in the center of the canvas.
- Fit Screen: The canvas size is automatically adjusted to fit the topology area size.
- Zoom 1:1: The canvas size equals the input source resolution.
- Display Grid: Display a grid on the canvas.
- Snap to Grid: The cabinet will be snapped to the grid.
- Snap to Cabinet: When positioning a cabinet near another one, the cabinet being moved will automatically align and snap to the edge of the adjacent cabinet, effectively eliminating gaps.
- Display Topology: Display the cabinet connections.
- Display Status: Display the cabinet status.
 - Green: The cabinet is in the canvas area.
 - Gray: The cabinet is offline.
 - Orange: Some part of the cabinet is in the canvas area.
 - Red: The entire cabinet is out of the canvas area.
- Display Cabinet Color: Display a color icon at the top right corner of an Ethernet port. Once an Ethernet port is loading cabinets, a color icon will be displayed which is of the same color as the cabinet color.
- Display Group Name: Display the cabinet group name.
- Display Overlapping Cabinets: Display the overlapping cabinets.

Figure 5-12 Online cabinet topology (VX2000 Pro)

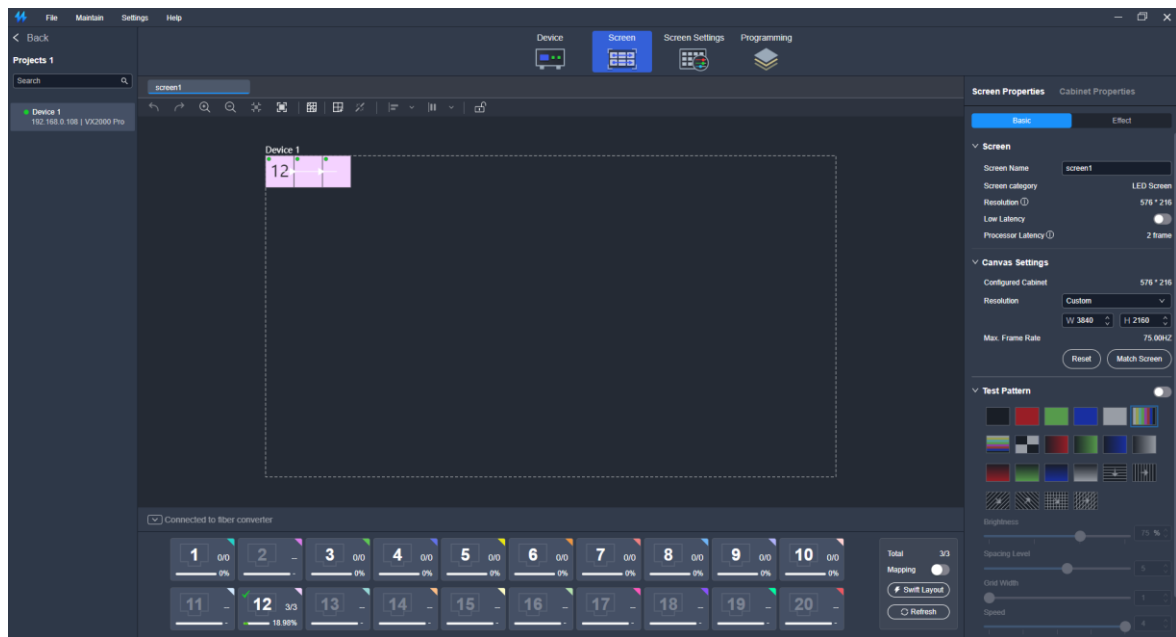

Note

- Use either Unico or NovaLCT to configure the screen.
- Mapping is used to show the relations between the cabinets of the LED screen and the sending devices so that you can view or check the connections between the cabinets.
- In the menu bar, go to **File > Export Screen Config File** to export the configured cabinet topology as a file (.scr).
- In the menu bar, go to **File > Import Screen Config File** to import a saved screen configuration file for quick topology.

5.4.2 Configure Screen Properties

Set the screen-related properties in the property area on the right pane.

5.4.2.1 Rename Screens

Change the screen name.

Prerequisites

None

Notes

None

Interface Example

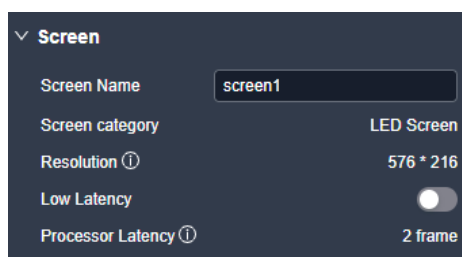

Description

On the **Basic** tab interface, enter a new screen name, and then click elsewhere in the interface to complete the screen name change.

5.4.2.2 Configure Low Latency

When the input source travels from where it comes to the processing device, sending device and then the receiving card, latency exists inevitably. Turning on this function can effectively help to reduce the latency from the input to output.

Prerequisites

None

Notes

To enable low latency, please make sure all Ethernet ports load the cabinets vertically and share the same Y coordinate. Free screen configuration (for example, Ethernet port 2 loads cabinets horizontally, or its Y coordinate is different from that of Ethernet port 1) will reduce the load capacity.

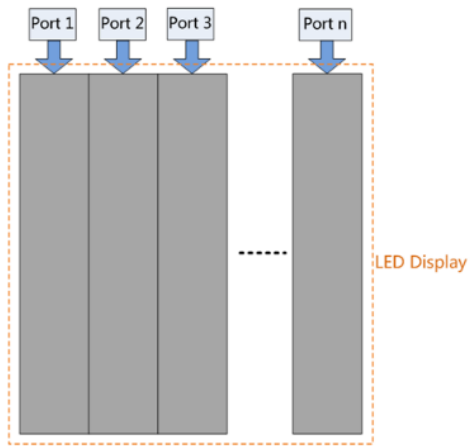

Interface Example

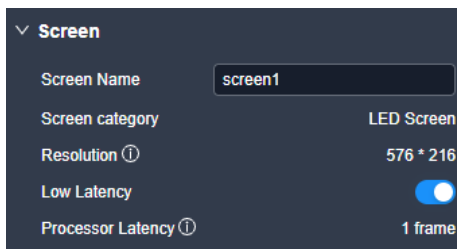

Description

| Parameter | Description |
|-------------|--|
| Low Latency | Turn on or turn off the function. <ul style="list-style-type: none"> <input checked="" type="checkbox"/>: On The device latency can be reduced by 1 frame. <input type="checkbox"/>: off |

5.4.2.3 Set Canvas Size

Prerequisites

None

Notes

None

Interface Example

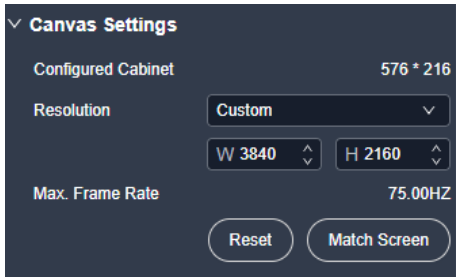

Description

On the **Basic** tab interface, configure the following parameters.

| Parameter | Description |
|--------------|---|
| Resolution | <p>The size of the canvas, that is the size of the device effective loading area</p> <p>Config method:</p> <ul style="list-style-type: none"> • Select the desired resolution from the drop-down list. • Select Custom from the drop-down list, and then set the width and height values. <p>Generally, the size of the effective loading area should match with that of the physical screen.</p> <p>After you complete the settings, the system will automatically calculate the max output frame rate at the current resolution.</p> |
| Match Screen | <p>After the screen configuration is completed, click Match Screen and the system will automatically change the canvas size to the size of the circumscribed rectangles.</p> |

5.4.2.4 Configure Test Patterns

Test patterns are used to check the connection relation between the output connectors and the screen, and check whether the screen display is good.

Prerequisites

None

Notes

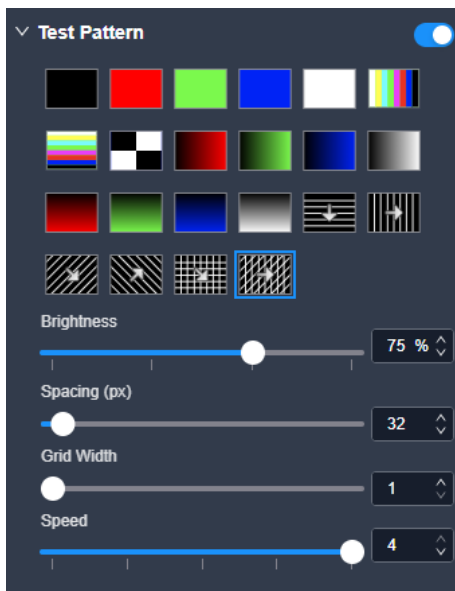

None

Interface Example



Description

On the **Basic** tab interface, configure the following parameters.

| Parameter | Description |
|---------------|---|
| Test Pattern | Turn on or turn off the function. <ul style="list-style-type: none"> • : On • : Off After the function is enabled, select the desired test pattern. |
| Brightness | Set the brightness of the test pattern. |
| Spacing Level | Set the spacing between different color areas. If a multi-color test pattern is selected, this parameter is available. |
| Spacing (px) | Set the spacing between the lines. If a grid test pattern is selected, this parameter is available. |
| Grid Width | Set the width of the grid lines. |
| Speed | Set the moving speed of the lines. |

5.4.2.5 Configure Output Color

Configure the output color parameters.

Prerequisites

None

Notes

Note

Interface Example

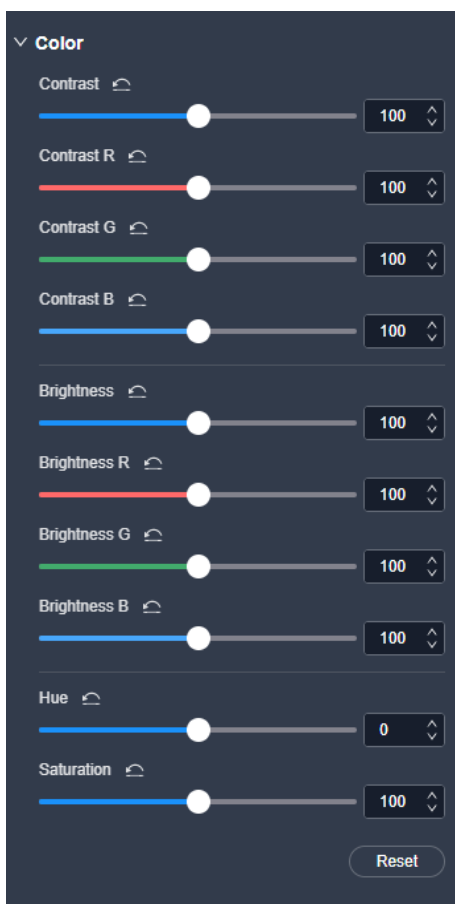

Description

On the **Effect** tab interface, configure the following parameters.

| Parameter | Description |
|------------|--|
| Contrast | The ratio of the luminance of the brightest color to that of the darkest color Adjust the contrast value either as a whole or individually adjust the RGB components. |
| Brightness | The shading of lights in the image Adjust the brightness value either as a whole or individually adjust the RGB components. |
| Hue | The relative degree of how bright or dark the image is |
| Saturation | The color purity of the image The higher the value, the more vivid the color. |

5.4.3 Configure Cabinet Properties

5.4.3.1 View Cabinet Info

View cabinet-related info.

Prerequisites

None

Notes

None

Interface Example

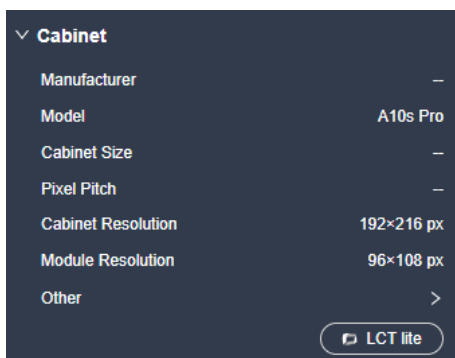

Description

None

 **Note**

Click **LCT Lite** to run the software in which you can configure the receiving card parameters.

5.4.3.2 Configure Cabinet Groups

Change the cabinet group name and background color.

Prerequisites

A cabinet group has been created.

Notes

None

Interface Example

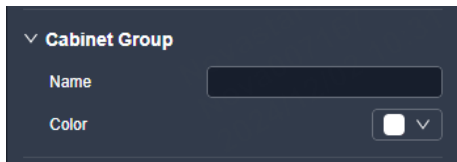

Description

On the **Cabinet Properties** tab interface, configure the following parameters.

| Parameter | Description |
|-----------|---|
| Name | The name of the cabinet group Config method: Enter a new group name, and then click elsewhere in the interface to complete the group name change. |
| Color | The background color of the group name Config method: Click the color block next to Group Color , and then select a standard color or enter RGB values to set the background color of the cabinet group name. |

5.4.3.3 Configure Cabinet Positions

Prerequisites

None

Notes

The cabinet rotation in 90° increments feature is only supported by certain models of receiving cards, as detailed below:

| Model | Description |
|---------------------------|---------------------------------|
| CA50E, XA50Pro, A10s Pro | Supported by all versions. |
| A8s-N, A7s Plus, A5s Plus | Supported by V4.9.0.0 or later. |

Interface Example

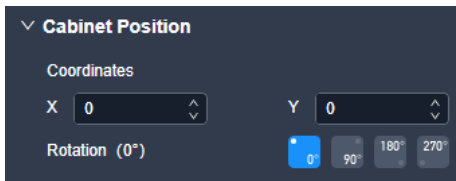

Description

On the **Cabinet Properties** tab interface, configure the following parameters.

| Parameter | Description |
|---------------|---|
| Coordinates | <p>The position of the cabinet on the canvas</p> <ul style="list-style-type: none"> • X: X coordinate of the cabinet on the canvas • Y: Y coordinate of the cabinet on the canvas |
| Rotation (0°) | <p>Rotate the cabinet. Once the cabinet is rotated, the input source will display at the adjusted angle.</p> <p>Supported rotation angles: 0°, 90°, 180° and 270°</p> |

5.4.3.4 Set Cabinets

Prerequisites

None

Notes





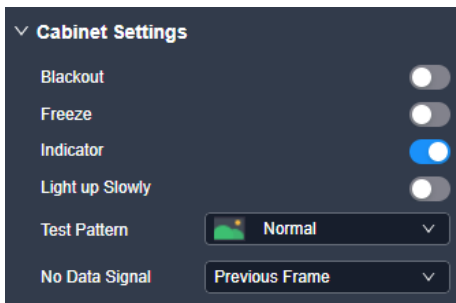



None

Interface Example



Description

On the **Cabinet Properties** tab interface, configure the following parameters.

| Parameter | Description |
|-----------------|--|
| Blackout | Turn on or turn off the function. <ul style="list-style-type: none"> • : On • : Off |
| Freeze | Turn on or turn off the function. <ul style="list-style-type: none"> • : On • : Off |
| Indicator | Turn on or turn off the function. <ul style="list-style-type: none"> • : On • : Off |
| Light up Slowly | Turn on or turn off the function. <ul style="list-style-type: none"> • : On • : Off |

| Parameter | Description |
|----------------|--|
| | Once enabled, the display brightness will slowly change from 0 to the target value after the screen is powered on. |
| Test Pattern | Select a test pattern to perform screen aging test and troubleshoot problems. |
| No Data Signal | Set the display image after the Ethernet cable is disconnected. <ul style="list-style-type: none"> • Blackout: The screen displays a black image. • Previous Frame: The screen always displays the last frame. |

5.4.3.5 Configure Ethernet Port Backup

Test whether the pre-stored images, backup Ethernet ports and devices take effect without plugging and unplugging the Ethernet cables.

Prerequisites

The pre-stored images, primary and backup Ethernet ports or primary and backup devices have been configured.

Notes

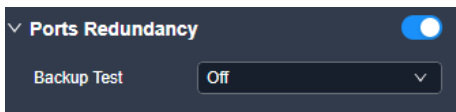

None

Interface Example



Description

On the **Cabinet Properties** tab interface, configure the following parameters.

| Parameter | Description |
|------------------|---|
| Ports Redundancy | Turn on or turn off the function. <ul style="list-style-type: none"> • : On • : Off |

| Parameter | Description |
|-------------|--|
| Backup Test | <p>Select the desired backup test.</p> <ul style="list-style-type: none"> • Off: Enable the output of all the Ethernet ports on the current device to complete the test. • Backup Only: Disable the output of the primary Ethernet port on the current device to test whether the backup port or device takes effect. • Primary Only: Disable the output of the backup Ethernet port on the current device to test whether the output of the primary port is normal. • Disconnect All: Disable the output of all the Ethernet ports on the current device to test whether the pre-stored image takes effect. |

Note

After enabling Ethernet port backup, a  icon is displayed between the primary and backup ports in the Ethernet port list. By default, the first half of the ports serve as backups for the second half.

5.5 Screen Settings

5.5.1 Adjust Image Quality

Adjust the Gamma value and brightness of the output to enhance the overall image quality of the LED screen.

Prerequisites

None

Notes

None

Interface Example

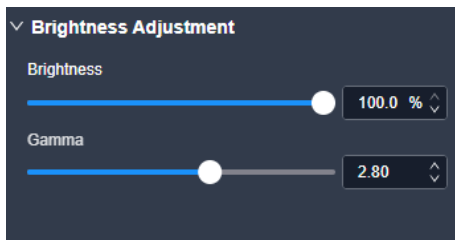

Description

Select **Screen Settings** at the top of the page, and then on the **Image Quality** tab interface, configure the following parameters.

| Parameter | Description |
|------------|---|
| Brightness | The brightness of the LED screen |
| Gamma | Adjust the ratio of the screen brightness to the input level. The parameters are read from the receiving card, which default to optimal values at the factory. It is recommended the parameter adjustment be carried out by the trained personnel when necessary. |

5.5.2 Adjust Output

5.5.2.1 Configure 3D

Directly connect a third-party 3D emitter using the device's built-in 3D connector, or connect to the EMT200 emitter via the device's Ethernet port. Then, use the compatible 3D glasses to achieve a 3D display effect.

Prerequisites

- Video source format: Side-by side, top-and-bottom or frame sequential.
- When paired with the EMT200, it is recommended to use a 3D source of 60Hz to enjoy an optimal experience.

Notes

- Enabling the 3D function will halve the device output capacity.

- The 3D function and input cropping cannot be enabled at the same time.
- After enabling the 3D function on the **Screen Settings** page, 3D switches of all the layers will be toggled on. If you want to use a 2D layer, please toggle off the 3D switch of the desired layer in the property area of the **Programming** page.
- The 3D effect follows the layer. The output area where a 3D layer is located always displays the 3D effect.

Interface Example

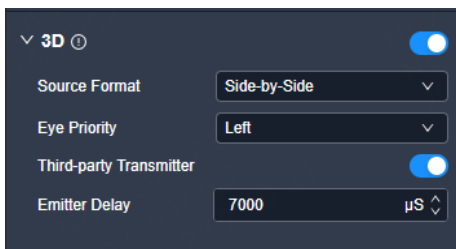

Description

On the **Output** tab interface, configure the following parameters.

| Parameter | Description |
|---------------------|--|
| 3D | Turn on or turn off the 3D function. <ul style="list-style-type: none"> • : On • : Off |
| Source Format | The format of the 3D video source Set the format to Side-by-Side , Top-and-Bottom or Frame Sequential according to the format of the accessed video source. |
| Eye Priority | Set which image is sent first, the right eye image or the left eye image. Put on the 3D glasses to view the screen. If the display appears abnormal, adjust the parameter value to the other one. If the display is normal, no further adjustments are needed. |
| Third-Party Emitter | Turn on or turn off the function. <ul style="list-style-type: none"> • : On • : Off |
| Emitter Delay | Set the delay time of sending the synchronization signal from the 3D signal emitter to the 3D glasses. This setting ensures that the switching between left and right eye images of the 3D glasses is in sync with the switching between the left and right eye images on the screen. This parameter is applicable to both the NovaStar and third- |

| Parameter | Description |
|-----------|-----------------|
| | party emitters. |

5.5.2.2 Check Load

Check the capacity usage of each Ethernet port of the device.

Prerequisites

None

Notes

None

Interface Example

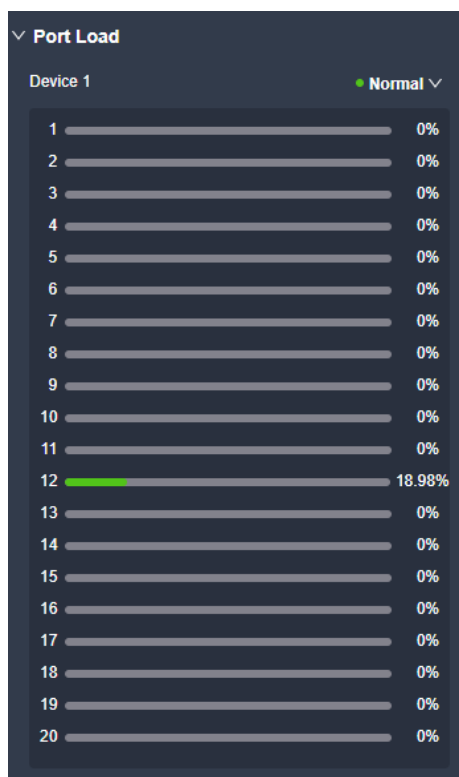

Description

On the **Output** tab interface, click  next to the device information to check the usage of the device loading capacity.

5.6 Layer Operations

5.6.1 Add Layers

Add layers to screen

Prerequisites

Make sure the device is in **Video Controller** mode before adding layers.

Notes

The maximum number of layers that can be added depends on the connected device.

| Device Model | Number of Supported Layers (2K×1K) |
|--------------|------------------------------------|
| VX2000 Pro | 12 |

Operating Procedure

Step 1 Select a device on the left side of the interface and then click **Programming** at the top of the page.

Figure 5-13 Programming (VX2000 Pro)

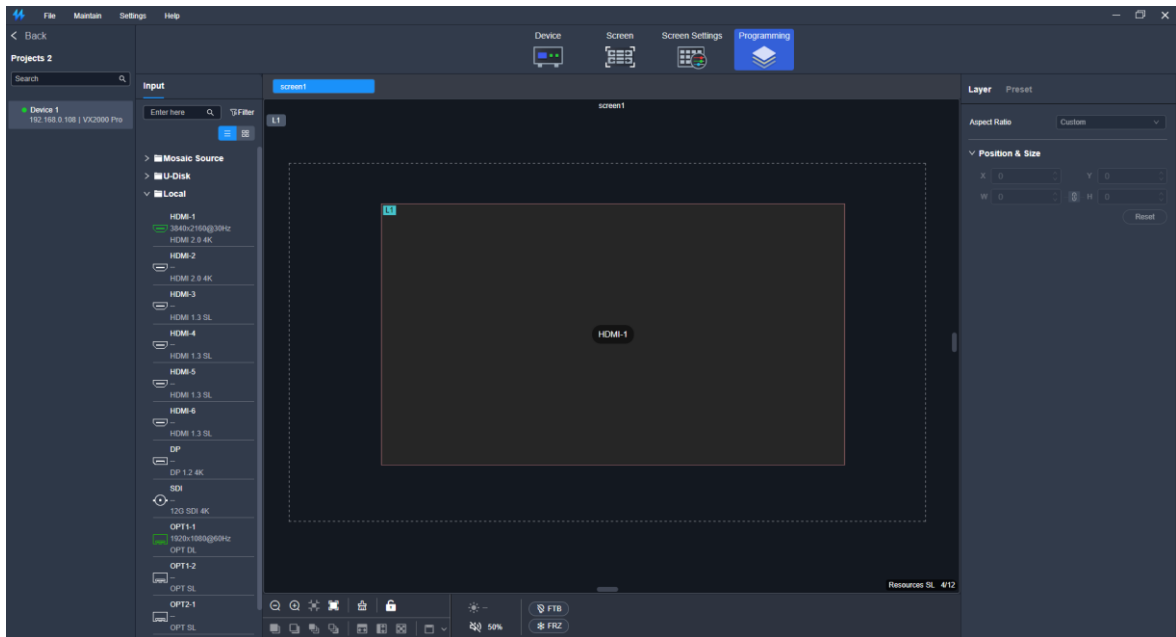

Step 2 Add the layers to the screen.

Drag an input source in the input list to the screen.

Step 3 Perform the desired layer operations as required.

Figure 5-14 Layer operations

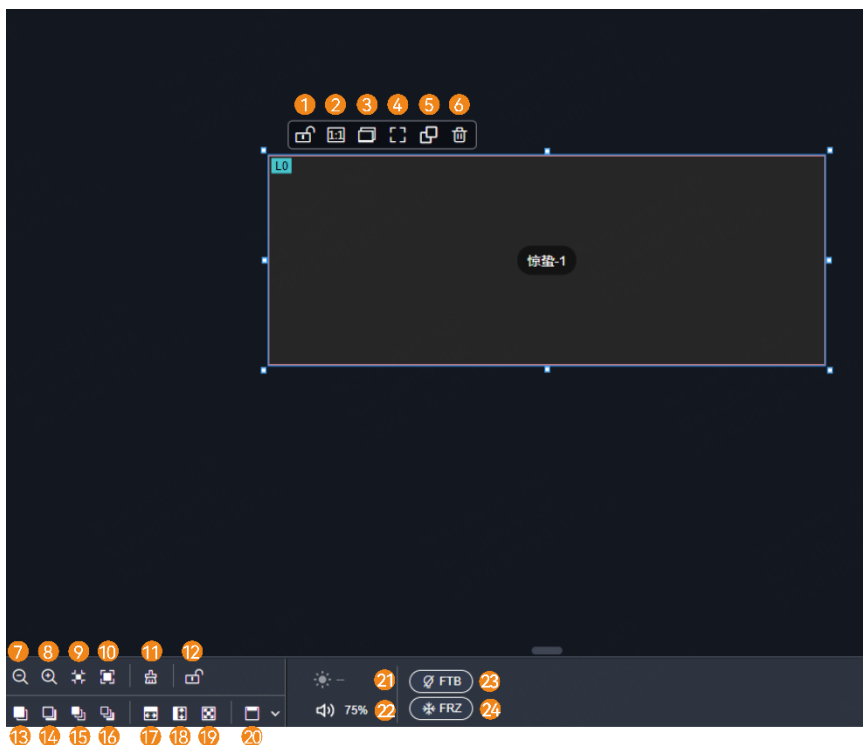

- 1 Lock/unlock layer
- 2 Pixel-to-pixel display
- 3 Fill entire screen
- 4 Fill canvas
- 5 Follow canvas
- 6 Delete layer
- 7 Zoom Out
- 8 Zoom In
- 9 Zoom to Selection
- 10 Auto fit
- 11 Clear
- 12 Lock/unlock canvas
- 13 Bring forward
- 14 Send backward
- 15 Bring to front
- 16 Send to back
- 17 Fill horizontally
- 18 Fill vertically
- 19 Fill entire screen
- 20 Align top
- 21 Output image brightness
- 22 Layer source volume
- 23 FTB
- 24 Freez/unfreeze

5.6.2 Configure Video Source Properties

In the input list, select an input source and set the relevant properties on the right pane. For detailed configurations and parameter descriptions, please refer to [Configure Input Properties](#).

5.6.3 Mosaic Source Settings

Both HDMI and OPT sources support mosaicing.

5.6.3.1 View Mosaic Source Info

View the basic properties of the mosaic source and change the source name.

Prerequisites

A mosaic source has been configured and its signal is fine.

Notes

None

Interface Example

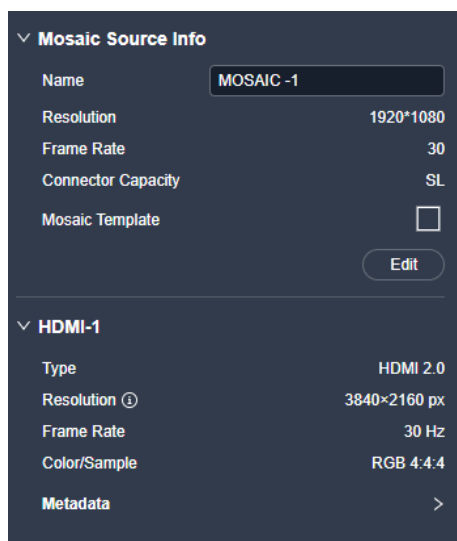

Description

On the **Mosaic** tab, type in a new source name and click anywhere else on the interface to save the change.

5.6.3.2 Configure Mosaic Sources

Set the mosaic source name, sub-source type, mosaic layout as well as sub-source size.

Prerequisites

None

Notes

Only the input sources of the same connector type support mosaicing, and the frame rates of sub-source must be the same.

Interface Example

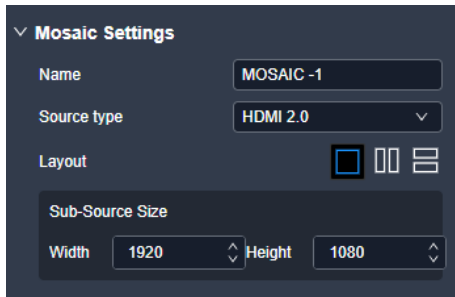

Description

On the **Edit Mosaic** tab interface, configure the following parameters.

| Parameter Name | Description |
|----------------|---|
| Name | The name of the mosaic source |
| Source Type | The type of the sub-sources Config method: Select HDMI 1.3 , HDMI 2.0 or OPT from the drop-down list. |
| Layout | The layout of the mosaic source |

| Parameter Name | Description |
|-----------------|--|
| | Config method: Select the desired layout from the standard layout template, and then drag the inputs in the input list to the sub-cells respectively. |
| Sub-Source Size | <p>The size of the sub-sources</p> <ul style="list-style-type: none"> • Default width: 1920 pixels, max width: 8192 pixels • Default height: 1080 pixels, max height: 8192 pixels • Max width and height: 4096×2160 |

5.6.4 Configure USB Source Properties

Select a USB source in the input list and configure relevant properties on the **USB Playback Settings** tab interface.

The models of devices that support USB playback and the corresponding output resolutions for USB sources are listed below.

| Device Model | USB Source Resolution |
|--------------|-----------------------|
| VX2000 Pro | 3840×2160@60Hz |

5.6.4.1 Play USB Files

Prerequisites

The U-DISK connector on the front panel is inserted with a USB drive which is successfully identified.

Notes

None

Interface Example

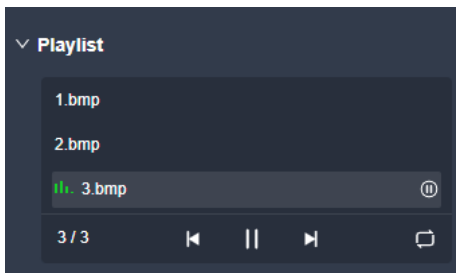

Description

In the playlist, select a file to play it and you can also stop the playback, play the previous or next file as well as set the playback mode.

5.6.4.2 Configure Playback Parameters

Prerequisites

The U-DISK connector on the front panel is inserted with a USB drive which is successfully identified.

Notes



None

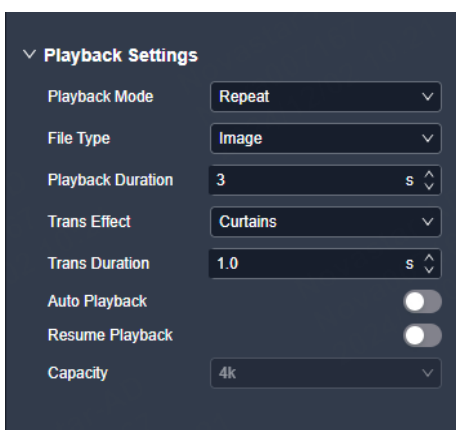

Interface Example



Description

On the **Settings** tab interface, configure the following parameters.

| Parameter | Description |
|-------------------|---|
| Playback Mode | The playback mode of the file <ul style="list-style-type: none"> • Repeat: Play the files in the playlist in order. Once the playback of the last file is completed, replay the first file. • Repeat in Order: Play the files in the playlist in order. Once the playback of the last file is completed, the screen will display a black image and the playback will stop. • Repeat One: Loop playback of the current file. |
| File Type | The type of the playback file <ul style="list-style-type: none"> • Video • Image • All: Video and Image <div style="background-color: #f0f0f0; padding: 5px; margin-top: 10px;">  Note </div> After the file type is selected, only the file of the selected type will be displayed in the playlist. |
| Playback Duration | The duration of the image playback The value ranges from 1 to 60 and it defaults to 5. (Unit: s) |
| Trans Effect | The trans effect of the image Supported trans effect: Ripple, zoom in, push, flip, blinds, H wipe, V wipe, cube, dissolve, grid, swapping, scroll, fade in/out, twirl, heart trans, curtains, perspective triangle, disappear, bounce, star rotation |
| Trans Duration | The trans duration of the image The value ranges from 0.5 to 2 and it defaults to 0.5. (Unit: s) |
| Auto Playback | The auto playback switch Set whether to automatically play the USB files after the device is powered off and then power on with a USB drive inserted. <ul style="list-style-type: none"> • : On If Resume Playback not enabled, replay the files in the playlist in order; If enabled, replay the file being played before power failure from the beginning. <ul style="list-style-type: none"> • : Off |
| Resume Playback | Turn on or turn off the function. |

| Parameter | Description |
|-----------|---|
| | <ul style="list-style-type: none"> •  On If a file is playing before the device power failure, enabling this function allows to replay the file from beginning after the device is powered on with a USB drive inserted. •  Off: Replay the files in the playlist in order. <div style="background-color: #f0f0f0; padding: 5px; margin-top: 10px;"> <p> Note</p> <ul style="list-style-type: none"> • Enabling Resume Playback will also activate the Auto Playback feature at the same time. • After Resume Playback is enabled, if the file being played before power failure cannot be found, the files will be played from the beginning of the playlist in order. </div> |

5.6.5 Configure Layer Properties

Select the desired layer, and then set the layer-related properties in the property area on the right pane.

5.6.5.1 Configure Basic Properties

Configure the layer name, aspect ratio, position, size, as well as enabling the 3D effect.

Prerequisites

None

Notes

After enabling the 3D function on the **Screen Settings** page, 3D switches of all the layers will be toggled on. If you want to use a 2D layer, please toggle off the 3D switch of the desired layer in the property area of the **Programming** page.

Interface Example

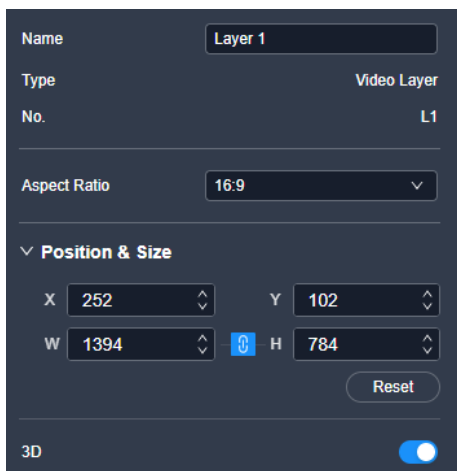

Description

On the **Basic** tab interface, configure the following parameters.

| Parameter | Description |
|--------------|--|
| Name | The layer name |
| Aspect Ratio | The ratio of the layer's width to its height After the aspect ratio is changed, the height of the layer remains unchanged, and the device automatically calculates its width. |
| X | The horizontal starting position of the layer on the screen The coordinates of the first pixel in the upper left corner of the screen are (0,0). |
| Y | The vertical starting position of the layer on the screen The coordinates of the first pixel in the upper left corner of the screen are (0,0). |
| W | The horizontal size of the layer The minimum width of a layer: 64 pixels |
| H | The vertical size of the layer The minimum height of a layer: 64 pixels |
| 3D | Turn on or turn off the function <ul style="list-style-type: none"> • <input checked="" type="checkbox"/>: On • <input type="checkbox"/>: Off |

5.6.5.2 Crop Layer Sources

When there are black borders or other redundant info in the input source image, the required picture can be retained through the cropping the input source, so as to improve the screen utilization.

Prerequisites

A fine signal is connected to the input connector.

Notes

- The status and capacity of the cropped source remain consistent with the original one.
- The input cropping and 3D functions cannot be enabled at the same time.

Interface Example

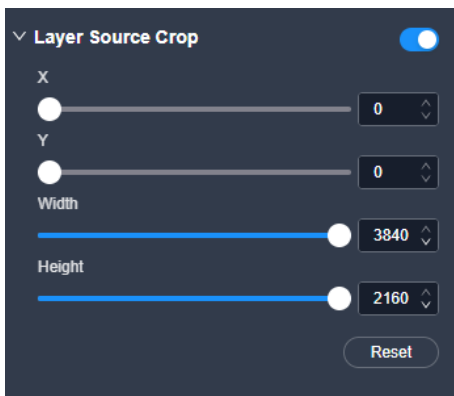

Description

On the **Advanced** tab interface, configure the following parameters.

| Parameter | Description |
|-------------------|---|
| Layer Source Crop | Turn on or turn off the function. <ul style="list-style-type: none"> • : On • : Off |
| X | The horizontal start position of the cropped area relative to the original source |
| Y | The vertical start position of the cropped area relative to the original source |

| Parameter | Description |
|-----------|---|
| Width | The number of horizontal pixels (width) of the cropped area |
| Height | The number of vertical pixels (height) of the cropped area |

5.6.6 Manage Presets

To manage the presets, click **Preset** on the right side of the Programming interface and perform the corresponding actions as needed.

Save Presets

- Step 1 On the **Preset** tab interface, click **Save Preset** at the bottom, and then a pop-up window will appear showing the preset numbers.

Figure 5-15 Bind presets (VX2000 Pro)

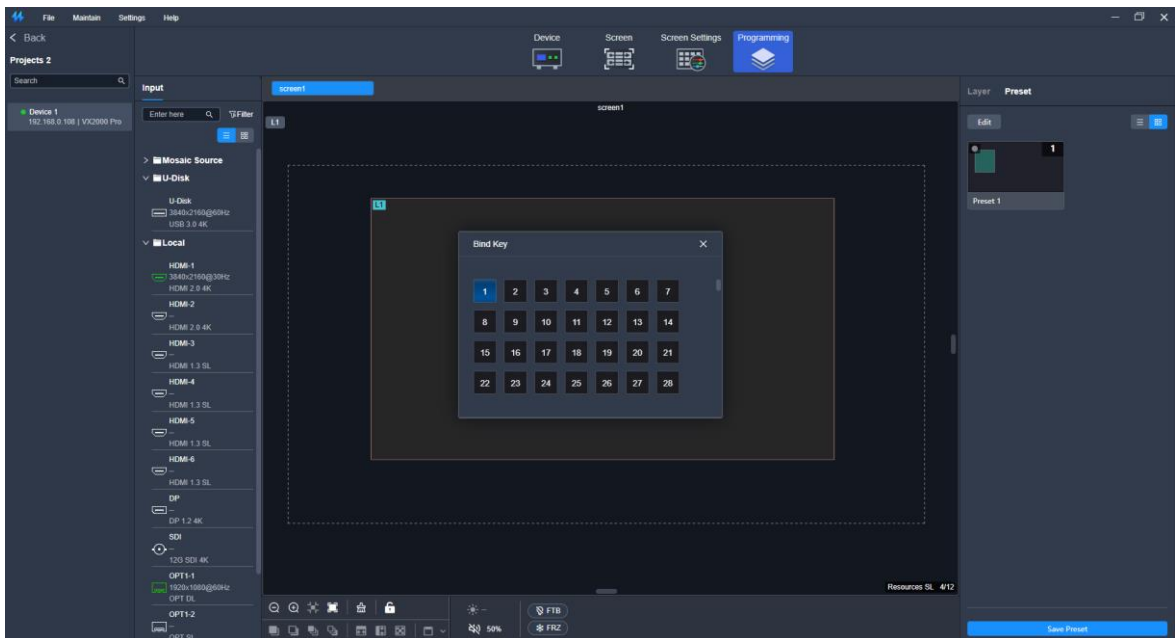



- Step 2 In the **Bind Key** window, select the desired key number to save the current layer information to the preset.

One key number corresponds to one preset. The name of the save preset: Preset X ("X" refers to the bound key number.)

Load Presets

In the preset list, select the desired preset to load it.

After the preset is successfully loaded, the corresponding indicator light at the top left of the preview area will light up:

- : The preset is not loaded.
- : The preset is loaded.

Rename Presets

Place the mouse over the preset and click . Enter a new name and then click elsewhere to make the change take effect.

Delete Single Presets

Place the mouse over the preset and click . In the pop-up dialog box, click **Yes**.

Delete All Presets

Click **Edit**, check **Select All**, and click . In the pop-up dialog box, click **Yes**.

5.7 Maintenance

5.7.1 Device Maintenance

In the menu bar, select **Maintain**. Select the **Device** tab and the target devices, and then do the following as required.

Figure 5-16 Device maintenance (VX2000 Pro)

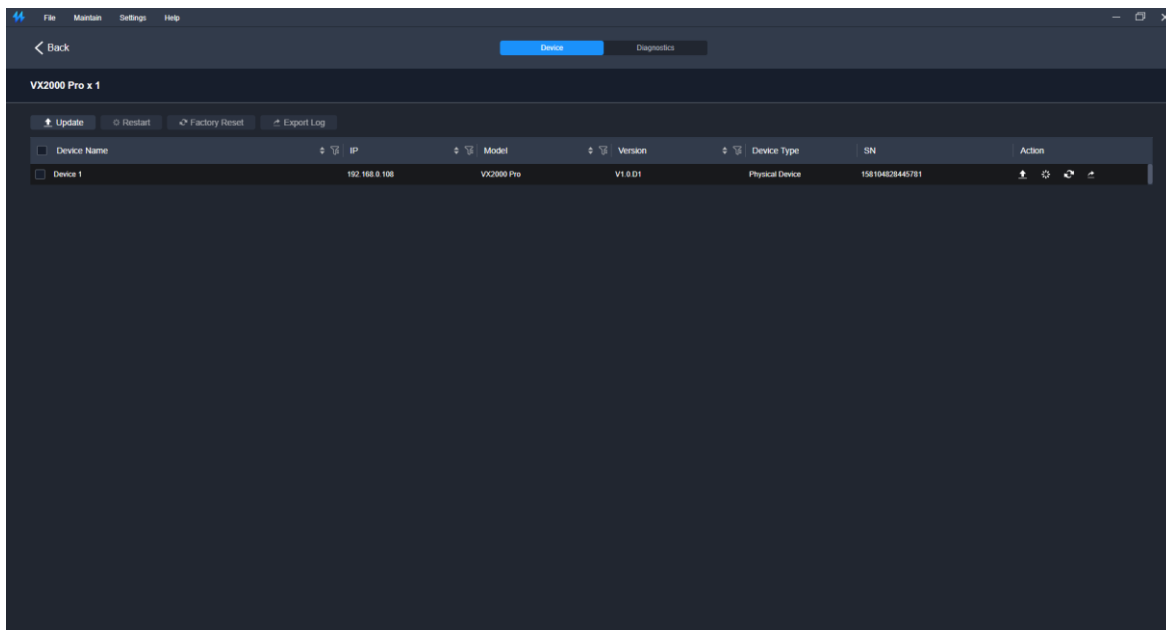

Update



Caution

During the update process, power-off and all operations are NOT allowed.

- Step 1 Click **Update**.
- Step 2 In the pop-up dialog box, select the update file (.img) and click **OK**.
- Step 3 Confirm the devices to be updated, and click the **Update** button.
- Step 4 In the pop-up dialog box, click **Yes** and wait until the update completes.
- Step 5 After the update completes, click **OK**.

Restart

Click **Restart**. In the displayed dialog box, click **Yes** to restart the device.

Factory Reset

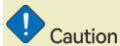

Caution

- Please do this with great caution.
- The reset action does not affect the device firmware version.

- Power-off is NOT allowed during the reset process.
- The device will restart automatically after the reset is completed.

Click **Factory Reset**. In the pop-up dialog box, select **Keep user data** or **Reset all**, and then click **OK**.

- Keep user data

Retain the device IP address, input connector EDID, gallery files, device language settings, device name and belonged project.

- Reset all

Retain the device IP address and belonged project.

Figure 5-17 Factory reset

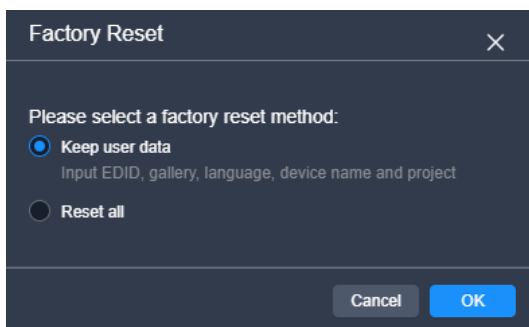

Export Logs

Click **Export Log**. In the dialog box that appears, select a path and click **Save** to save the device logs to local computer.

5.7.2 Device Diagnostics

In the menu bar, select **Maintain**. Select the **Diagnostics** tab, select a device from the drop-down list, and click **Diagnostics**.

After the diagnostics completes, you can view the test result and take necessary measures as required.

Figure 5-18 Device diagnostics (VX2000 Pro)

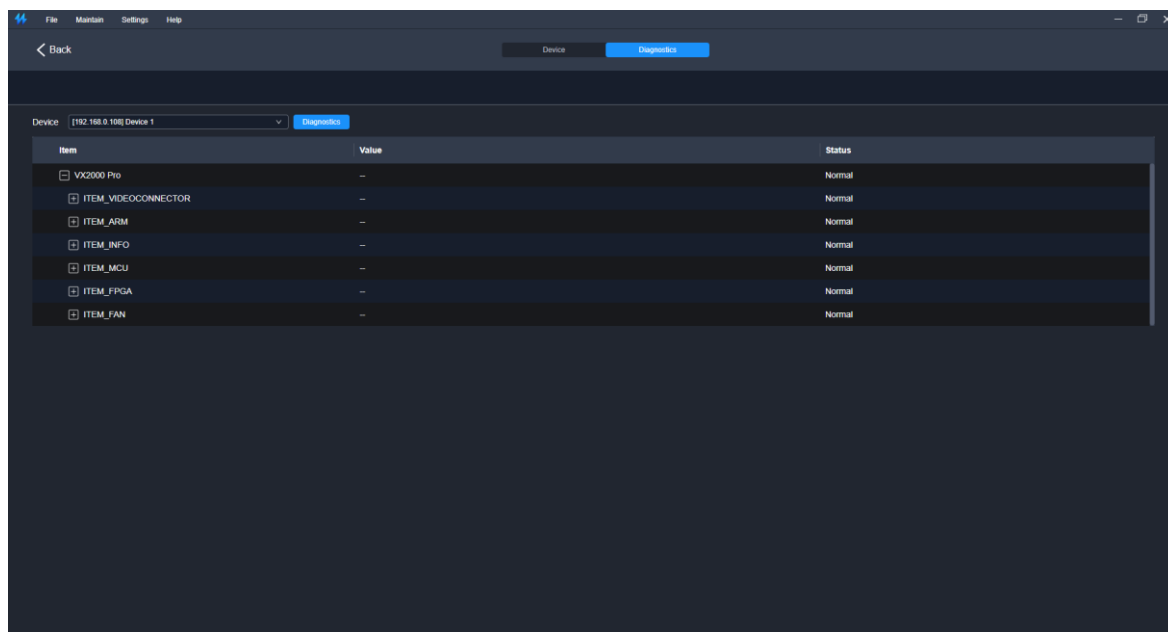

5.8 Software Settings

5.8.1 Switch UI Language

In the menu bar, go to **Settings** > **Language** to switch the UI language.

5.8.2 Export Logs

In the menu bar, go to **Settings** > **Export Log** to export the logs of the Unico software.

5.8.3 Configure Device Backup

Device backup allows you to set the backup relationship between two devices. You can set one of the devices as the primary device or the backup device. When the primary device has a problem or the primary device's Ethernet cable fails, the backup device will take over the responsibilities of the primary device seamlessly and continue to work well to ensure the LED screen will not go black.

Prerequisites

- Before creating a backup relation, make sure that both the primary and backup devices are on the same LAN.
- In a backup relation, the models and device versions of the primary and backup devices must be the same.

Notes

- You have three options to create a backup relation: NovaLCT, Unico, or the device LCD menu. However, be aware that these methods do not synchronize with each other. Using more than one can lead to data problems. To prevent issues, choose only one method for setting up your backup. If you do mix them, you'll need to reset the device to factory settings and start over with just one method.
- In the device backup mode, the quantity of the cabinets loaded by each Ethernet port on both the primary and backup devices must be the same, but their data flow must be in a reversed way.

Operation Procedure

Step 1 In the menu bar, go to **Settings > Device Backup**.

Step 2 In the pop-up window, click **Add** to add a backup relation.

Figure 5-19 Add backup relations

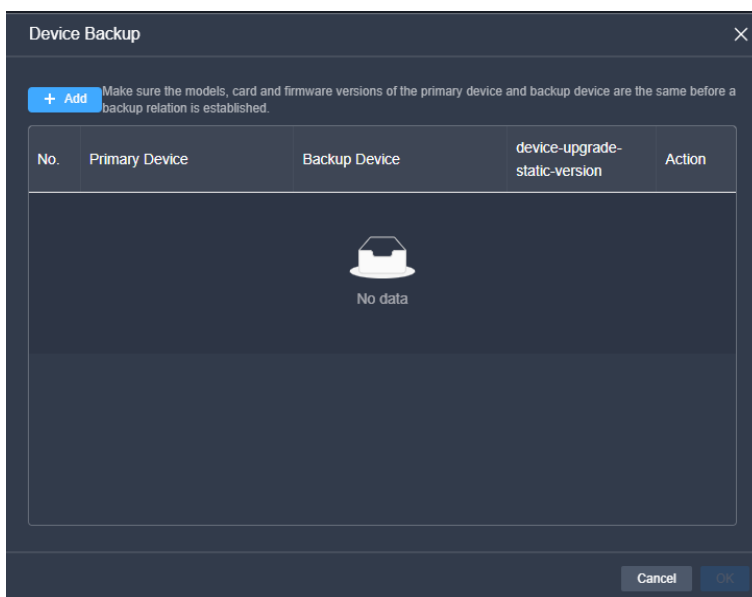

Step 3 Select the primary and backup devices from the drop-down lists respectively.

After the action completes, the firmware versions of the primary and backup devices will be displayed.

Step 4 Click **OK** to complete the backup relation settings.

Step 5 (Optional) Click **Delete** to delete the desired backup relation.

5.8.4 Manage Cabinet Library

In the menu bar, go to **Settings > Cabinet Library**. Do the followings as needed to manage the cabinet library files.

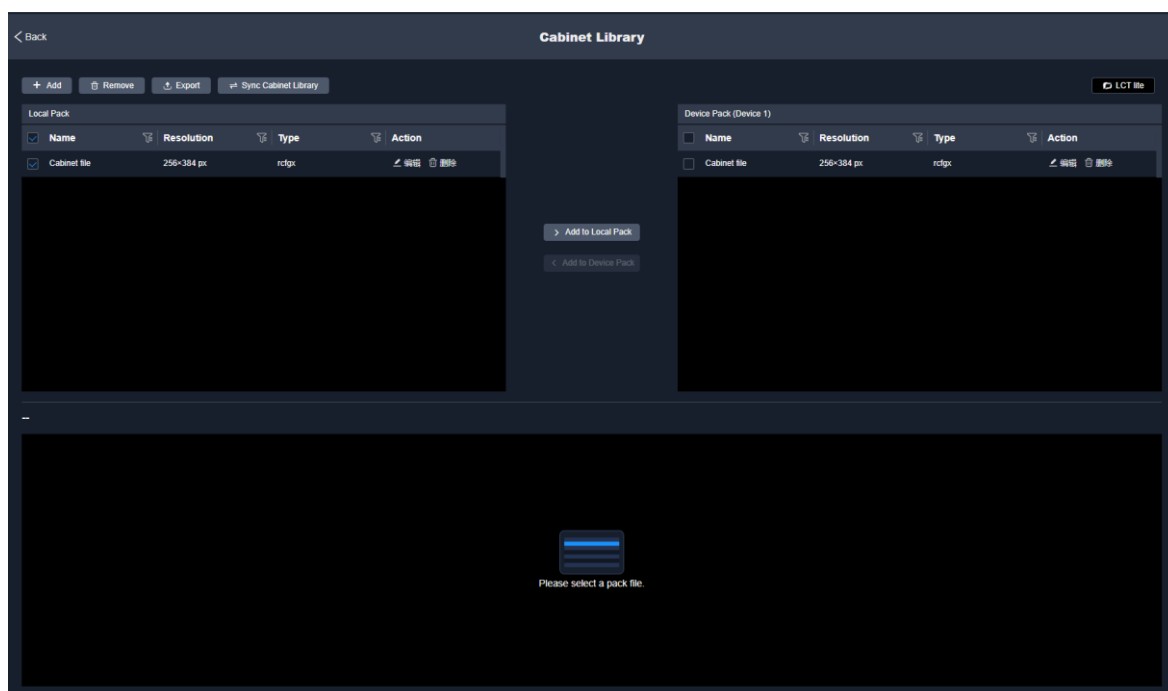

Upload Cabinet Files

Step 1 Click **Add** and select the cabinet type in the displayed window.

The cabinet types are as follows.

- Cabinet File (rcfgx)
- Virtual Cabinet: If **Virtual Cabinet** is selected, you need to configure the parameters such as cabinet name, resolution width and height.

Figure 5-20 Cabinet file

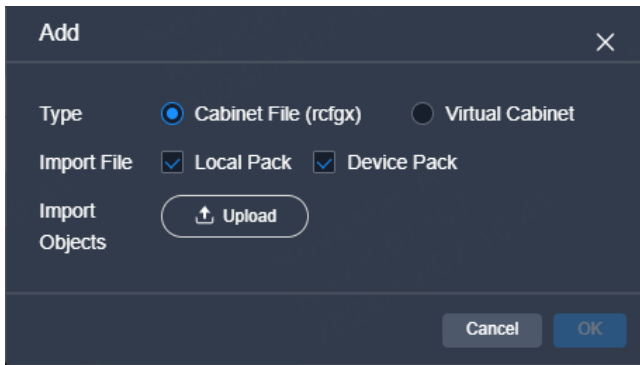
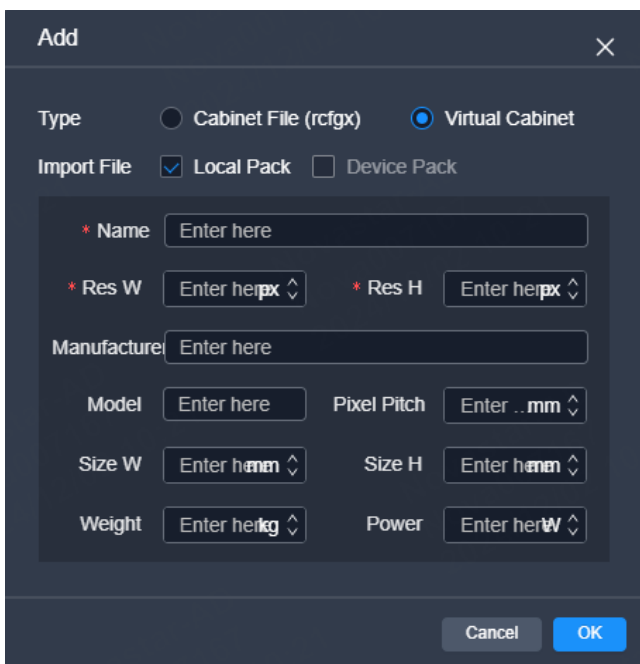

Figure 5-21 Virtual Cabinet



Step 2 Select the object to be imported.

- When **Local Pack** is selected, the file will be stored in the Unico installation directory.
Virtual cabinet files can be imported to the local pack only.
- When **Device Pack** is selected, the file will be stored in the internal space of the device.

Step 3 Select the .rcgx file to be imported from the local computer and click **Upload**.

After the file is selected, you can click **Delete** to delete the uploaded file.

Export Cabinet Files

Step 1 Select one or more files on the **Cabinet Library** interface and then click **Export**.

For batch export, multiple files will be compressed as a .zip file and exported.

Step 2 Select a local directory and click **Save**.

Sync Cabinet Files

- Sync cabinet files between the device and local computer.

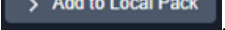
Select the files to be synced (multiple files can be selected), and click 

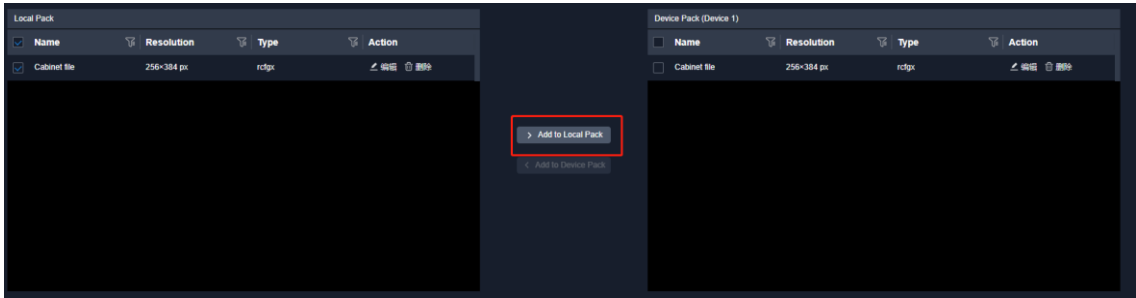

- Sync cabinet files between devices
 - 1) Select the files to be synced (multiple files can be selected), and click **Sync Cabinet Library**.
 - 2) On the displayed window, select the devices to which the files are synced (multiple devices can be selected).



- 3) Click **OK**.

View Cabinet and Flash Info

Select a cabinet file, and the information about all the cabinets that use this cabinet file will be displayed.

5.8.5 Configure Preferences

In the menu bar, navigate to **Settings > Preferences**. Turn on the desired features (checked "✓") or off (unchecked).

- Screen Resources: Show the layer resources on the **Programming** interface if enabled.

5.8.6 View Software Info

In the menu bar, go to **Help > About Us** to view the software-related info.

6 Copyright

Copyright © 2024 Xi'an NovaStar Tech Co., Ltd. All Rights Reserved.

No part of this document may be copied, reproduced, extracted or transmitted in any form or by any means without the prior written consent of Xi'an NovaStar Tech Co., Ltd.

Trademark

 is a trademark of Xi'an NovaStar Tech Co., Ltd.

Statement

Thank you for choosing NovaStar's product. This document is intended to help you understand and use the product. For accuracy and reliability, NovaStar may make improvements and/or changes to this document at any time and without notice. If you experience any problems in use or have any suggestions, please contact us via the contact information given in this document. We will do our best to solve any issues, as well as evaluate and implement any suggestions.

| Official website
| www.novastar.tech

| Technical support
| support@novastar.tech