

TCC160

Asynchronous Full-Color LED Display Control Card



Specifications

Change History

Document Version	Release Date	Description
V1.0.3	2024-09-26	Updated the certification information.
V1.0.2	2024-09-13	Changed the maximum height of an ultra-long screen.
V1.0.1	2024-09-04	Added receiving card features.
V1.0.0	2024-08-28	First release

Introduction

The TCC160 is an asynchronous full-color LED display control card from NovaStar. It integrates sending and receiving capabilities, allowing users to publish content and control LED displays with a computer, mobile phone, or tablet. Working with cloud-based publishing and monitoring platforms, the TCC160 enables users to manage LED displays from an Internet-connected device anywhere, anytime.

The TCC160 comes with 16 standard HUB75E connectors for communication. The hardware and software designs take into full consideration the on-site setup, operation and maintenance, making setup easier, operation more stable, and maintenance more efficient.

Thanks to its stable and secure integrated design, the TCC160 saves space, simplifies cabling, and is suitable for the applications requiring small pixel capacity, such as storefront displays, vehicle-mounted displays, displays in communities, and lamp-post displays.

Certifications

CE, FCC, RoHS

If the product does not have the relevant certifications required by the countries or regions where it is to be sold, please contact NovaStar to confirm or address the problem. Otherwise, the customer shall be responsible for the legal risks caused or NovaStar has the right to claim compensation.

Features

Inputs and Outputs

- For PWM driver ICs, the maximum pixel capacity per TCC160 is 512×512@60Hz. For general driver ICs, the maximum pixel capacity per TCC160 is 512×384@60Hz.
Maximum width/height: 2048 pixels (capacity not exceeding 260,000 pixels)
- Maximum capacity when multiple TCC160 cascaded: 650,000 pixels
Maximum width/height: 2048 pixels (pixel capacity not exceeding 650,000)

- Maximum width of an ultra-long screen: 8192 pixels, Maximum height of an ultra-long screen: 2048 pixels (maximum capacity per Ethernet port: 650,000 pixels)
- 1x Stereo audio output

Control

- 1x USB 2.0 (Type A) port
Allows for upgrade, USB playback, storage expansion, and log export.
- 1x USB (Type B) port
Connects to the control computer for content publishing and screen control.
- 2x RS485 connectors
Connect to light sensors, temperature and humidity sensors, or other modules to implement corresponding functions.

Performance

- Powerful processing capacity
 - Industrial-grade processor
 - Quad-core 1.4 GHz processor
 - Hardware decoding of 4K videos
 - 2 GB of RAM
 - 32 GB of internal storage
- Flawless playback
Support for playback of 1x 4K, 3x 1080p, 8x 720p, 10x 480p, or 16x 360p videos

Functionality

- All-round control plans
 - Allows users to publish content and control screens from a computer, mobile phone, or tablet.
 - Allows users to publish content and control screens from anywhere, anytime.
 - Allows users to monitor screens from anywhere, anytime.
- Wi-Fi AP and Wi-Fi STA can be turned on at the same time
 - Wi-Fi AP allows the built-in Wi-Fi hotspot of the TCC160 to be connected. The default SSID is “AP+ *Last 8 digits of SN*” and the default password is printed on the SSID label of the product.
 - Wi-Fi STA allows users to access the TCC160 directly and connect the TCC160 to the Internet.
- Ultra-long-screen content playback
- Synchronous playback across multiple screens
Enabling synchronous playback halves the decoding capability of the device.
 - NTP time synchronization
 - GPS time synchronization
- Support for 4G modules

The TCC160 ships without a 4G module. Users have to purchase 4G modules separately if needed.

- Support for GPS positioning and GPS time synchronization
- Support for relay (maximum DC 30 V 3 A)

Receiving Card Features

- Up to 32 groups of parallel RGB data or 64 groups of serial data (expandable to 128 groups of serial data)
- Color management
Supports Standard (Rec.709 / DCI-P3 / Rec.2020) and custom color gamuts, enabling more precise colors on the screen
- 18bit+
Improves the LED display grayscale by 4 times to avoid grayscale loss due to low brightness and allow for a smoother image.
- Low latency (This feature is turned off by default)
The latency of video source on the receiving card end can be reduced to 1 frame (only when using modules with driver IC with built-in RAM).
- Individual Gamma adjustment for RGB
Working with NovalCT and the controller that supports this function, the receiving card supports individual adjustment to red gamma, green gamma and blue gamma, which can effectively control image non-uniformity at low grayscale conditions and white balance offset, allowing for a more realistic image.
- 90° Image rotation
The display image can be rotated in multiples of 90° (0°/90°/180°/270°).
- Display of three color 16 pixels serial input
Supports display of the three color 16 pixels serial input of PWM chips
- Temperature and voltage monitoring
Real-time monitoring of the temperature and voltage of the receiving card, without the need for other external devices.
- Bit error detection
The Ethernet port communication quality of the receiving card can be monitored and the number of erroneous packets can be recorded to help troubleshoot network communication problems.
- Firmware program readback
The receiving card firmware program can be read back and saved to the local storage.
- Configuration parameter readback
The receiving card configuration parameters can be read back and saved to the local storage.
- Mapping 1.1 (available for cascaded receiving cards)
The cabinets can display the controller number, receiving card number, and Ethernet port information, allowing users to easily obtain the locations and connection topology of receiving cards.
- Dual program backup
Two copies of firmware program are stored in the receiving card at the factory to avoid the problem that the receiving card may get stuck abnormally during program update.

Appearance

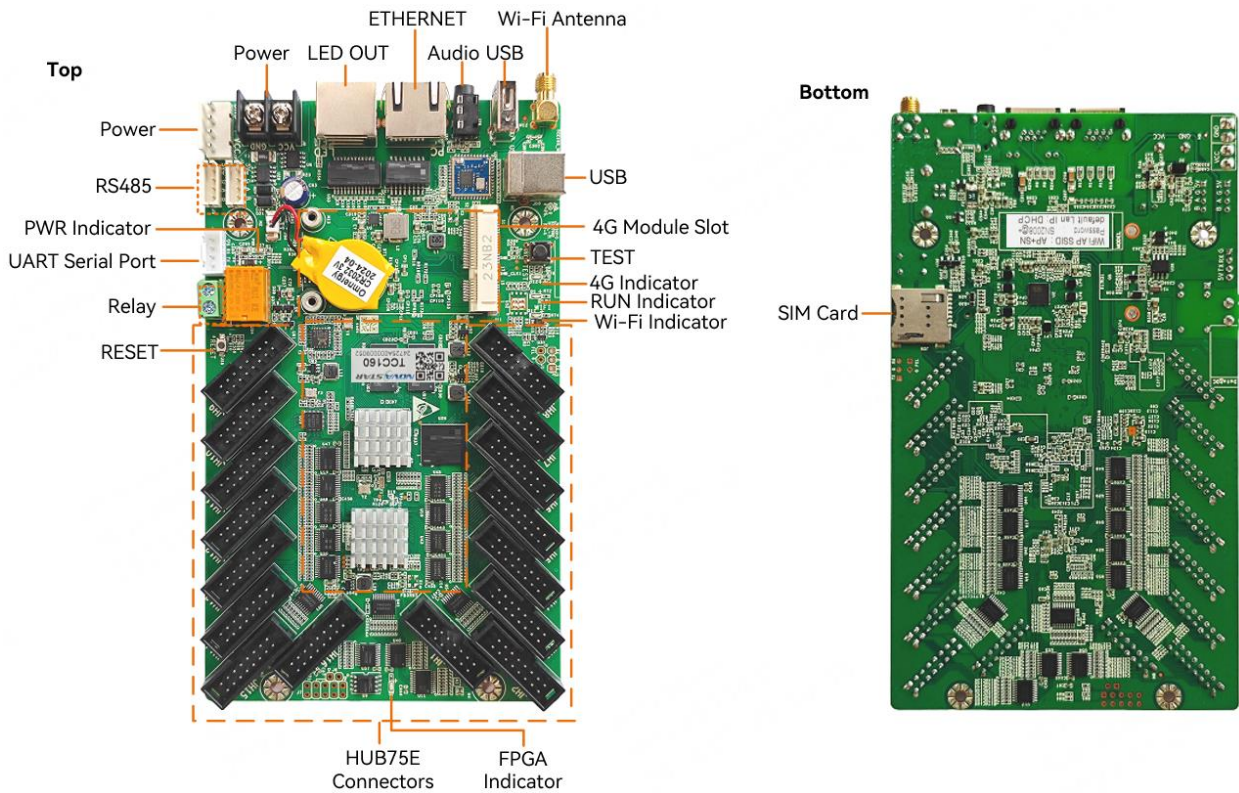

All product pictures shown in this document are for illustration purpose only. Actual product may vary.

Table 1-1 Connectors and buttons

Name	Description
Power	Power input connector
LED Out	Gigabit Ethernet port Standard RJ45 connector (with no built-in LEDs) for cascading receiving cards Multifunction cards cannot be connected.
ETHERNET	Fast Ethernet port Standard RJ45 connector (with built-in LEDs) connecting to a network or control computer
Audio	Audio output connector OMTP headphones can be connected.
USB	<ul style="list-style-type: none"> 1x USB 2.0 (Type A) port allowing for upgrade, USB playback, storage expansion (up to 128 GB), and log import and export. <p>Only the FAT32 file system is supported and the maximum size of a single file is 4 GB.</p>

Name	Description
	<ul style="list-style-type: none"> 1x USB (Type B) port connecting to the control computer for content publishing and screen control.
Wi-Fi Antenna	Wi-Fi antenna connector (2.4 GHz Wi-Fi supported)
SIM Card	<p>SIM card slot</p> <p>Capable of preventing users from inserting a SIM card in the wrong orientation.</p>
HUB75E Connectors	<p>HUB75E connectors</p> <p>Connect to LED modules.</p>
Relay	2-pin relay control switch for remote screen control
UART Serial Port	<p>Reserved port</p> <p>Connects to a third-party GPS module for positioning and time synchronization</p>
RS485	<p>RS485 connectors</p> <p>Connect to light sensors, other sensors or modules to implement corresponding functions.</p>
RESET	<p>Factory reset button</p> <p>Press and hold this button for 5s to reset the device to the factory settings.</p>

Indicators

Indicator	Color	Status	Description
PWR	Red	Staying on	The power supply is working properly.
4G	Green	Staying on	The network connection and device communication is normal.
		Flashing once every second	The SIM card is abnormal.
		Off	No 4G module is detected.
RUN	Green	Flashing once every 2s	The system is functioning normally.
		Staying on/off	The system is malfunctioning.
WiFi	Green	Staying on	Built-in Wi-Fi Sta is turned on, but no Wi-Fi network is connected.
		Flashing once every 2s	Wi-Fi Sta is configured and a Wi-Fi network is

			connected successfully.
		Off	Wi-Fi Sta is turned off.
FPGA	Green	Flashing once every second	The receiving card is working properly, the Ethernet cable connection is normal, and there is a video input.
		Flashing 3 times every 0.5s	The Ethernet cable connection is normal but there is no video input.
		Flashing once every 0.2s	Loading of the program in the application area fails and the backup program is working.

Dimensions

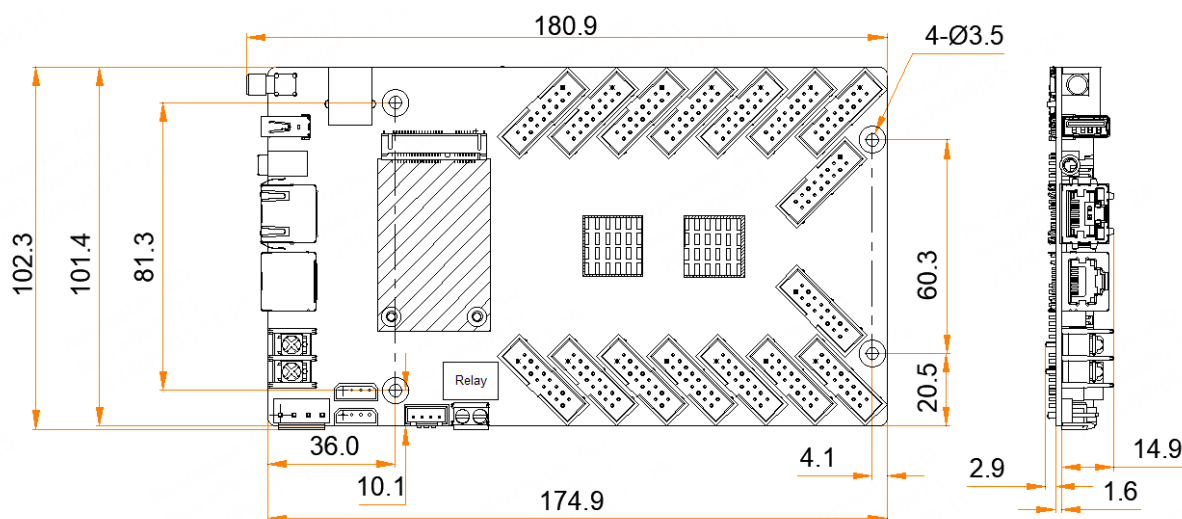

Tolerance: ±0.3 Unit: mm

To make molds or trepan mounting holes, please contact NovaStar for a higher-precision structural drawing.

Specifications

Electrical Parameters	Input voltage	5 V~12 V
	Maximum power consumption	12 W
Storage Capacity	RAM	2 GB
	Internal storage	32 GB
Operating Environment	Temperature	-40°C to +80°C
	Humidity	0% RH to 80% RH, non-condensing

Storage Environment	Temperature	-40°C to +80°C
	Humidity	0% RH to 80% RH, non-condensing
Physical Specifications	Dimensions (L×W×H)	180.9 mm × 102.3 mm × 19.4 mm
	Net weight	149.6 g
	Gross weight	348.6 g
Packing Information	Dimensions (L×W×H)	278.0 mm × 218.0 mm × 63.0 mm
	List	<ul style="list-style-type: none"> • 1x TCC160 • 1x Omnidirectional Wi-Fi antenna • 1x Quick Start Guide • 1x Certificate of Approval
System Software	<ul style="list-style-type: none"> • Android 10.0 operating system software • Android terminal application software • FPGA program 	

The amount of power consumption may vary depending on various factors such as product settings, usage, and environment.

Media Decoding Specifications

Image

Codec	Max Resolution	Format	Remarks
BMP	4096×2304 pixels	BMP	N/A
GIF	4096×2304 pixels	GIF	N/A
JPG	4096×2304 pixels	JPG	N/A
JPEG	4096×2304 pixels	JPEG	N/A
PNG	4096×2304 pixels	PNG	N/A

Audio

Codec	Channel	Bit Rate	Sampling Rate	Format	Remarks
MPEG1/2/2.5 Audio Layer1/2/3	2	8kbps~320kbps, CBR and VBR	8kHz~48kHz	MP1, MP2, MP3	N/A

Codec	Channel	Bit Rate	Sampling Rate	Format	Remarks
WMA Version 4/4.1/7/8/9, wmapro	2	8kbps~320kbps	8kHz~48kHz	WMA	No support for WMA Pro, lossless codec and MBR
MS-ADPCM, IMA-ADPCM, PCM	2	N/A	8kHz~48kHz	WAV	Support for 4bit MS-ADPCM and IMA-ADPCM
Q1~Q10	2	N/A	8kHz~48kHz	OGG, OGA	N/A
Compress Level 0~8	2	N/A	8kHz~48kHz	FLAC	N/A
ADIF, ATDS Header AAC-LC and AAC-HE, AAC-ELD	5.1	N/A	8kHz~48kHz	AAC, M4A	N/A
AMR-NB, AMR-WB	1	AMR-NB 4.75~12.2kbps@8kHz AMR-WB 6.60~23.85kbps@16kHz	8kHz, 16kHz	3GP	N/A
MIDI Type 0/1, DLS version 1/2, XMF and Mobile XMF, RTTTL/RTX, OTA, iMelody	2	N/A	N/A	XMF, MXMF, RTTTL, RTX, OTA, IMY	N/A

Video

Codec	Resolution	Maximum Frame Rate	Maximum Bit Rate (Ideal Case)	Format	Remarks
H.265	4096×2304 pixels	60fps	150Mbps	MKV, MP4, MOV, TS	Support for Main Profile, Tile & Slice
H.264	4096×2304 pixels	30fps	60Mbps	AVI, MKV, MP4, MOV, 3GP, TS, FLV	Support for Field Coding and MBAFF
H.263	1920×1080 pixels	60fps	60Mbps	3GP, MOV, MP4	No support for H.263+

Codec	Resolution	Maximum Frame Rate	Maximum Bit Rate (Ideal Case)	Format	Remarks
VP9	4096×2304 pixels	60fps	60Mbps	WEBM, MKV	N/A
VP8	1920×1080 pixels	60fps	60Mbps	WEBM, MKV	N/A
AVS2	4096×2304 pixels	60fps	60Mbps	MKV, MP4	N/A
MPEG4 SP	1920×1080 pixels	60fps	60Mbps	3GP, MP4, AVI	N/A
MPEG2 MP	1920×1080 pixels	60fps	60Mbps	MPEG-PS, MPEG-TS, MKV, AVI	N/A
MPEG1 MP	1920×1080 pixels	60fps	60Mbps	MPEG-PS, MPEG-TS, AVI, MKV	N/A
VC-1 SP	1920×1080 pixels	60fps	60Mbps	ASF, WMV, MKV, MP4	N/A
Xvid	1920×1080 pixels	60fps	60Mbps	AVI, MKV, MP4	N/A
Sorenson Spark	1920×1080 pixels	60fps	60Mbps	FLV, MP4	N/A
AVS/AVS+	1920×1080 pixels	60fps	30Mbps	TS, MP4, MKV	N/A
MJPEG	1920×1080 pixels	22fps	2Mbps	AVI	N/A

Note: The output data format supports YUV420 semi-planar. YUV400 (monochrome) is also supported by H.264.

Notes and Caution

FCC Cautions

This device complies with part 15 of the FCC rules. Operation is subject to the following two conditions: (1) this device may not cause harmful interference, and (2) this device must accept any interference received, including interference that may cause undesired operation.

Changes or modifications not expressly approved by the party responsible for compliance could void the user's authority to operate the equipment.

NOTE: this equipment has been tested and found to comply with the limits for a Class B digital device, pursuant to part 15 of the FCC Rules. These limits are designed to provide reasonable protection against harmful interference in a residential installation. This equipment generates uses and can radiate radio frequency energy and, if not installed and used in accordance with the instructions, may cause harmful interference to radio

communications. However, there is no guarantee that interference will not occur in a particular installation. If this equipment does cause harmful interference to radio or television reception, which can be determined by turning the equipment off and on, the user is encouraged to try to correct the interference by one or more of the following measures:

- Reorient or relocate the receiving antenna.
- Increase the separation between the equipment and receiver.
- Connect the equipment into an outlet on a circuit different from that to which the receiver is connected.
- Consult the dealer or an experienced radio/TV technician for help.

Radiation Exposure Statement

This equipment complies with FCC radiation exposure limits set forth for an uncontrolled environment. This equipment should be installed and operated with minimum distance 20 cm between the radiator and your body.

This transmitter must not be co-located or operating in conjunction with any other antenna or transmitter.

Country Code selection feature to be disabled for products marketed to the US/Canada.

- The antenna must be installed such that 20 cm is maintained between the antenna and users, and
- The transmitter module may not be co-located with any other transmitter or antenna.

As long as the three conditions above are met, further transmitter testing will not be required. However, the OEM integrator is still responsible for testing their end-product for any additional compliance requirements required with this module installed.

Copyright © 2024 Xi'an NovaStar Tech Co., Ltd. All Rights Reserved.

No part of this document may be copied, reproduced, extracted or transmitted in any form or by any means without the prior written consent of Xi'an NovaStar Tech Co., Ltd.

Trademark

 is a trademark of Xi'an NovaStar Tech Co., Ltd.

Statement

Thank you for choosing NovaStar's product. This document is intended to help you understand and use the product. For accuracy and reliability, NovaStar may make improvements and/or changes to this document at any time and without notice. If you experience any problems in use or have any suggestions, please contact us via the contact information given in this document. We will do our best to solve any issues, as well as evaluate and implement any suggestions.

| [Official website](http://www.novastar.tech)
| www.novastar.tech

| [Technical support](mailto:support@novastar.tech)
| support@novastar.tech