

MG Series

2K Distributed Processors

AV over IP System

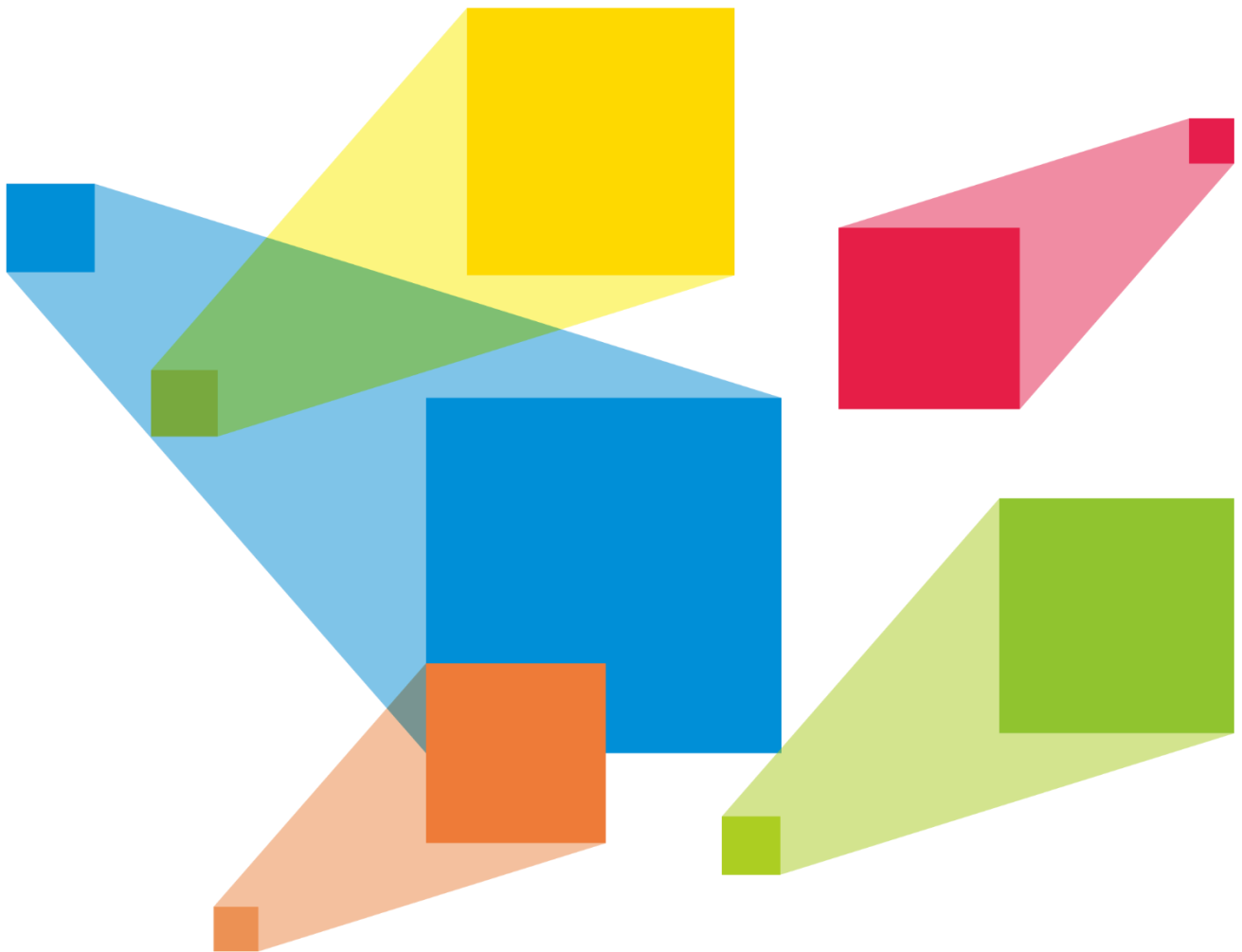

Specifications

Introduction

The MG series AV over IP system is a digitized distributed image processing and control system based on network. In the system, the encoders collect multiple audio and video signal sources scattered in different locations and transcode them into IP streams. The decoders receive the streams and display the corresponding information on the display devices to realize network sharing of audio and videos.

Adopting the H.264 and H.265 transmission protocols, the MG series system utilizes low network bandwidth and provides low-latency and high quality audio and video experience. Breaking the limitations of the traditional centralized deployment, the system is suitable for the decentralized deployment of audio and video interconnection applications across regions and networks.

The MG series system integrates long-distance digital audio and video transmission, signal switching, KVM operator and screen management. Working with the distributed visual management system and distributed KVM collaboration system, the MG series system can be applied in various visual application scenarios, such as control rooms, large conference communication centers, monitoring centers, data centers and dispatch centers.

Certifications

CCC, CE, FCC

If the product does not have the relevant certifications required by the countries or regions where it is to be sold, please contact NovaStar to confirm or address the problem. Otherwise, the customer shall be responsible for the legal risks caused or NovaStar has the right to claim compensation.

Key Features

High Image Quality, Low Latency

Adopting NovaStar's high-performance image processing technologies, the system has the characteristics of low bandwidth, low latency, high definition and high stability. The support for H.264 and H.265 video encoding helps achieve well balanced color sampling, processing and transmission of videos up to 10bit 4:2:2. The video transmission quality is extremely high, with the image transmission free of distortion and the original color saturation well maintained. The system latency is as low as 60 ms or less, realizing "what you see is what you get".

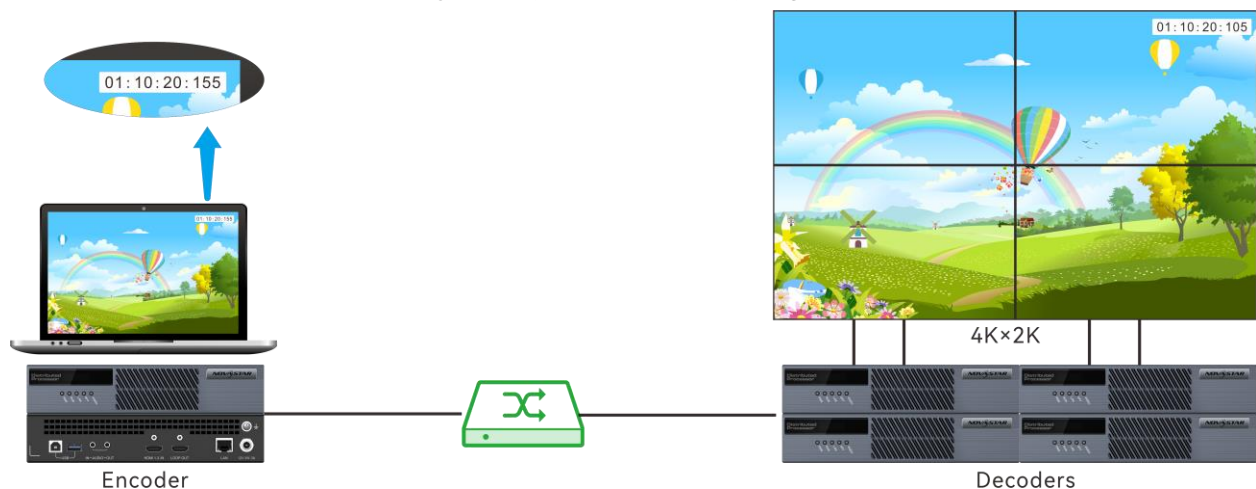

Output Mosaic from Multiple Decoders, Accurately Synchronized

The MG series decoders use unique synchronization technology to achieve full synchronization of output images of all decoders, which fundamentally eliminates the phenomena of asynchronization of mosaic images from different decoders or tearing when playing high speed moving videos.



Image Mosaic by Other Decoders



Image Mosaic by MG Series Decoders

KVM Control, Cross-Platform Roaming

The KVM management and cross-screen mouse roaming are supported. All operations can be done from the mouse, and the mouse cursor can move across windows and monitors, realizing simultaneous preview of multiple signal sources. In addition, different platforms (Windows, Linux and Mac OS) can be controlled from only one set of keyboard and mouse at the node.

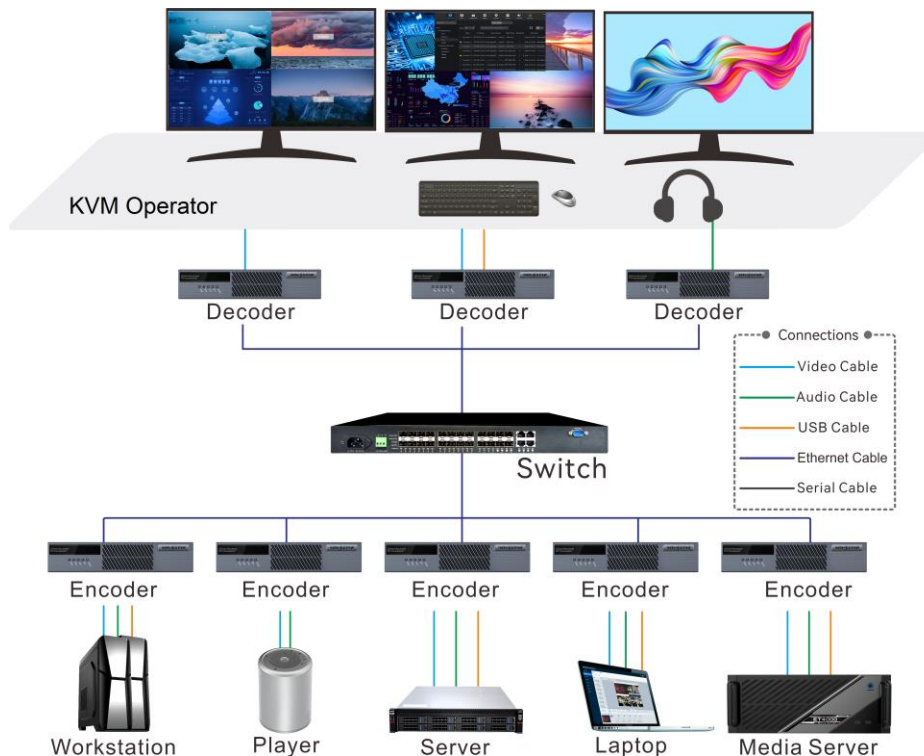

Signal Pushing and Capturing, Easy Collaboration

The MG series system supports signal pushing between operators or between the operators and LED screen, allowing the problems or images that need to be decided to be pushed to others or the LED screen. Through collaboration, the decision can be made timely and problems can be handled efficiently.

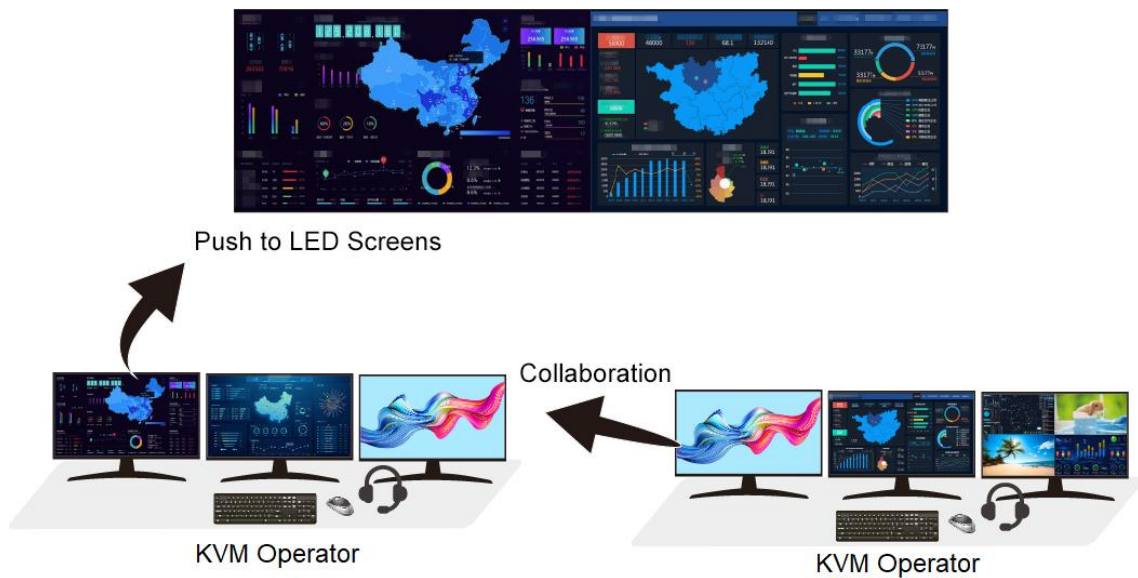

Web Control, Convenient Operation and Configuration

The management system supports configuration management through the Web, providing users with a simple and fast operation method and enabling cross-terminal operations. The web control includes device management, accurate permission assignment, input and output resolution management of encoders and decoders, LED screen management, firmware update and log management.



Product Features

- Discrete deployment, unified management

Multiple geographically scattered signal nodes can be quickly connected to the system for unified signal data control and management.
- Mass access, unlimited expansion

Thanks to its IP-based architecture, system nodes can be quickly increased based on the network and each node can access the network as long as an IP address is specified.
- Hierarchical permissions, secure management

The system supports role-based hierarchical user permission management. The administrator can configure different permissions for users, so that the operation permissions can be divided into the most detailed. In this way, different operators with different roles can perform different operations, which greatly improves work efficiency and security.
- Stable, secure and reliable

The decentralized design allows a single node to be used as an independent control center. Each node works independently and the control failure of a single node will not affect the operation of the entire system. Only the faulty node needs to be repaired. This ensures the stability of the entire system operation and facilitates system maintenance.
- Convenient implementation and easy maintenance

Encoders and decoders can be added directly to the system network to quickly expand the system, and the system automatically synchronizes system parameters without manual reconfiguration. Remote update and batch update are also supported.
- Man-device separation, tidy and efficient

The distributed processors are placed in the computer room for management, leaving space for the command and control center and avoiding a messy workspace and noise pollution in the past. It not only realizes man-device separation and allows one person to operate multiple devices, but also improves the processor data security.
- Visualized management and precise arrangement

The output images on the screens are fully visualized. Real-time preview of signal source images, screen layout and LED screen images are available to realize precise screen display arrangement, avoiding signal switching errors and thus improving the switching efficiency and realizing "what you see is what you get".
- Mouse roaming, one KVM operator with multiple screens, multiple signals on one screen

Each KVM operator can control multiple screens and each screen supports preview and control of up to 4 signal images. The operations on multiple monitors can be done from only one set of keyboard and mouse, greatly simplifying the desktop environment. While the operator is operating the local monitor data, the data and operation can also be displayed in real time on the LED screen or other display terminals.
- Multiple audio and video access
 - Supports access of signals in multiple formats, including HDMI, IP, Audio and more.
 - Supports access of various kinds of videos and is compatible with multiple resolutions.
 - Supports access of IP cameras using the ONVIF protocol and streaming media data using the RTSP protocol.
- Secure KVM operator management

The KVM operator can set permissions for different KVM groups, allowing KVMs in different groups to display specified data information and operators to operate the specified data information. This ensures system data security and meets the management requirements of high-security-level mission-critical projects.
- Flexible loading of LED screens
 - A single MGT600 drives up to 3.9 million pixels, with the width up to 10240 pixels and height up to 8192 pixels.
 - Supports backup between devices and Ethernet ports.
- Free layout of multiple layers

The screen loaded by a single device supports free layout of 4x 2Kx1K@30Hz, 2x 4Kx1K@30Hz and 1x 4Kx2K@30Hz to achieve flexible and excellent visual effects.
- Scrolling OSD text
 - Supports display of the static or dynamic OSD text on the LED screen.
 - Supports customized text content, font, color, size and background color of the OSD text.
 - Supports configurations of the text scrolling direction, initial position and speed.
- Customized presets and preset playlist playbacks
 - Supports management of multiple screens and presets.
 - Supports two preset playback modes. The options include loop and scheduled playback.
- Input source management
 - Supports customized group management of input sources.
 - Supports EDID settings for input sources.
 - Supports setting a logo for each input source.
 - Supports input source cropping.
 - Supports configurations of input source audio.
- Flexible audio options
 - Supports accompanied and independent audio inputs.

- Supports output of audio that comes with the layer. The audio output can be the accompanied audio or independent audio.
 - Supports output volume adjustment.
- Switch and use local signals on the OSD menu of the KVM operator system.
- Device IP displayed on the front panel screen
- System call for quick device locating
When the device is called, the indicators flash.
- Firmware update on Web page
- Device backup

Appearance

MG200 Encoder

Front Panel



No.	Area	Function
1	OLED screen	Displays the device IP address
2	Indicators	<ul style="list-style-type: none"> • PWR: Power indicator <ul style="list-style-type: none"> – On: The power supply is normal. – Off: The power supply is abnormal. • RUN: Running status indicator <ul style="list-style-type: none"> – Flashing: The device is functioning normally. – On/Off: The device is functioning abnormally. • LAN: Ethernet port connection status indicator <ul style="list-style-type: none"> – Flashing: The Ethernet port connection is normal. – Off: The Ethernet port connection is abnormal. • OPT: Reserved indicator • VIDEO: Video transmission and processing status indicator <ul style="list-style-type: none"> – On: The video stream processing is normal. – Off: The video stream processing is abnormal or there is no video stream. <p>Note When the device is called, the RUN, LAN and VIDEO indicators simultaneously flash.</p>

Rear Panel



Input Connectors		
Connector	Qty	Description
HDMI 1.3	1	<ul style="list-style-type: none"> • Input resolutions up to 1920x1080@60Hz • Up to 10bit 4:4:4 video input and processing • HDCP 1.4 and HDCP 1.3 compliant • EDID management supported

		<ul style="list-style-type: none"> - Width: 800 to 4088 pixels - Height: 600 to 4095 pixels • Accompanied audio supported
Audio Connectors		
AUDIO	2	1x AUDIO input, 1x AUDIO output <ul style="list-style-type: none"> • 3.5 mm standard analog audio connectors • Audio sampling rate: 22 kHz, 24 kHz, 44 kHz, 48 kHz (default) and 96 kHz • AAC audio encoding format supported • Dual channel with depth up to 24bit • Loop through of input connector audio
Output Connectors		
LAN	1	Gigabit Ethernet ports <ul style="list-style-type: none"> • It can be used for the transmission of the streaming media, control instructions and more. • Encoding style: HEVC and AVC • Protocols supported: rtsp, rtcp, rtp, and ONVIF Status LEDs: <ul style="list-style-type: none"> • The top left one indicates the connection status. <ul style="list-style-type: none"> - On: The port is well connected. - Flashing: The port is not well connected, such as loose connection. - Off: The port is not connected. • The top right one indicates the communication status. <ul style="list-style-type: none"> - On: The Ethernet cable is short-circuited. - Flashing: The communication is good and data is being transmitted. - Off: No data transmission <div style="background-color: #f0f0f0; padding: 5px; margin-top: 10px;"> <p> Note CAT5E and above standard wires are recommended.</p> </div>
LOOP OUT	1	Loop through of the HDMI input
Control		
USB	1	<ul style="list-style-type: none"> • Type-B USB 2.0: Connected to the input computer for keyboard, mouse and USB drive data transmission • Type-A USB 3.0: Reserved
Power connector	1	DC 12V 3A Connects to the external power outlet.

MG201 Decoder

Front Panel



No.	Area	Function
1	OLED screen	Displays the device IP address
2	Indicators	<ul style="list-style-type: none"> • PWR: Power indicator <ul style="list-style-type: none"> – On: The power supply is normal. – Off: The power supply is abnormal. • RUN: Running status indicator <ul style="list-style-type: none"> – On/Off: The device is functioning abnormally. – Flashing: The device is functioning normally. • LAN: Ethernet port connection status indicator <ul style="list-style-type: none"> – Flashing: The Ethernet port connection is normal. – Off: The Ethernet port connection is abnormal. • OPT: Reserved indicator • VIDEO: Video output indicator <ul style="list-style-type: none"> – On: The video output is normal. – Off: The video output is abnormal or there is no video output <p> Note</p> <p>When the device is called, the RUN, LAN and VIDEO indicators simultaneously flash.</p>

Rear Panel

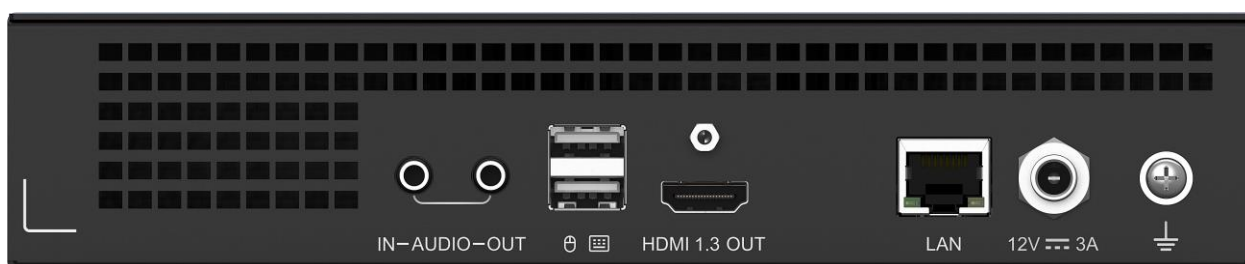

Output Connectors		
Connector	Qty	Description
HDMI 1.3 OUT	1	<ul style="list-style-type: none"> • Output resolutions up to 1920×1080@60Hz • Up to 10bit 4:4:4 video input and processing • HDCP 1.4 and HDCP 1.3 compliant • Accompanied audio output supported • EDID management supported <ul style="list-style-type: none"> – Width: 800 to 4096 pixels – Height: 600 to 4096 pixels
Audio Connectors		
AUDIO	2	1x AUDIO input, 1x AUDIO output <ul style="list-style-type: none"> • 3.5 mm standard analog audio connectors • Audio sampling rate: 22 kHz, 24 kHz, 44 kHz, 48 kHz (default) and 96 kHz • AAC audio encoding format supported • Dual channel with depth up to 24bit • Loop through of input connector audio • The audio output connector supports volume adjustment.
Transmission Connectors		
LAN	1	Gigabit Ethernet port <ul style="list-style-type: none"> • It can be used for receiving the streaming media, control instructions and more.

		<ul style="list-style-type: none"> • Encoding style: HEVC and AVC • Protocols supported: rtsp, rtcp, rtp, and ONVIF <p>Status LEDs:</p> <ul style="list-style-type: none"> • The top left green one indicates the connection status. <ul style="list-style-type: none"> – On: The port is well connected. – Flashing: The port is not well connected, such as loose connection. – Off: The port is not connected. • The top right yellow one indicates the communication status. <ul style="list-style-type: none"> – On: The Ethernet cable is short-circuited. – Flashing: The communication is good and data is being transmitted. – Off: No data transmission <p> Note</p> <p>CAT5E and above standard wires are recommended.</p>
Control		
USB	2	USB 2.0 connectors Connect to the mouse and keyboard.
Power connector	1	DC 12V 3A Connects to the external power outlet.

MGT600 All-in-One Decoder

Front Panel



No.	Area	Function
①	OLED screen	Displays the device IP address.
②	Indicators	<ul style="list-style-type: none"> • PWR: Power indicator <ul style="list-style-type: none"> – On: The power supply is normal. – Off: The power supply is abnormal. • RUN: Running status indicator <ul style="list-style-type: none"> – Flashing: The device is functioning normally. – On/Off: The device is functioning abnormally. • LAN: Ethernet port connection status indicator <ul style="list-style-type: none"> – Flashing: The Ethernet port connection is normal. – Off: The Ethernet port connection is abnormal. • OPT: Reserved indicator • VIDEO: Video out indicator <ul style="list-style-type: none"> – On: The video output is normal. – Off: The video output is abnormal or there is no video output. <p> Note</p> <p>When the device is called, the RUN, LAN and VIDEO indicators simultaneously flash.</p>

Rear Panel

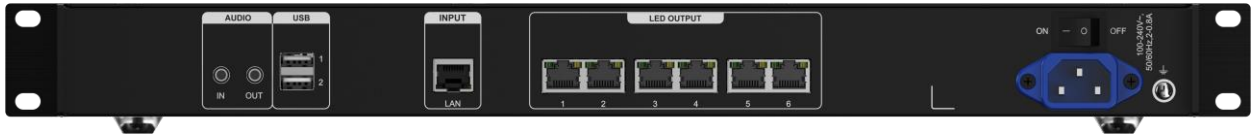

Area	Connector	Description
AUDIO	IN	3.5 mm analog audio input connector <ul style="list-style-type: none"> Audio sampling rate: 22 kHz, 24 kHz, 44 kHz, 48 kHz (default) and 96 kHz AAC audio encoding format supported Dual channel with depth up to 24bit
	OUT	3.5 mm audio output connector <ul style="list-style-type: none"> Audio sampling rate: 22 kHz, 24 kHz, 44 kHz, 48 kHz (default) and 96 kHz AAC audio encoding format supported Dual channel with depth up to 24bit The audio output connector supports volume adjustment.
USB	USB	2x USB 2.0 ports Reserved
INPUT	LAN	Gigabit Ethernet port It can be is used for receiving the streaming media, control instructions and more. It can be used for screen configuration with NovaLCT.
LED OUTPUT	Ethernet port	6x Gigabit Ethernet ports for LED screen loading It can drive up to 3.9 million pixels, with the width up to 10240 pixels and height up to 8192 pixels.

Applications

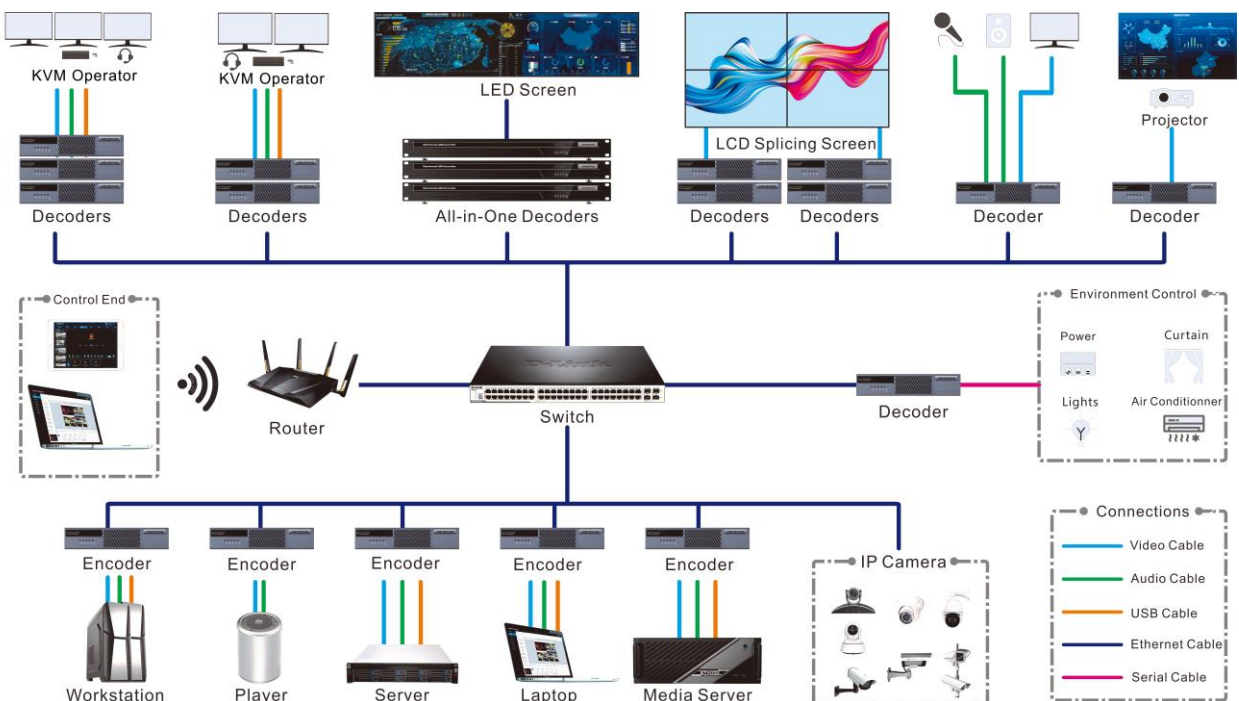

Dimensions

MG200 & MG201

The MG200 and MG201 devices have the same size.

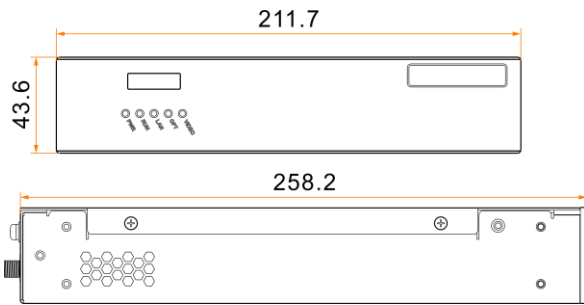

Tolerance: ± 0.3 Unit: mm

MGT600

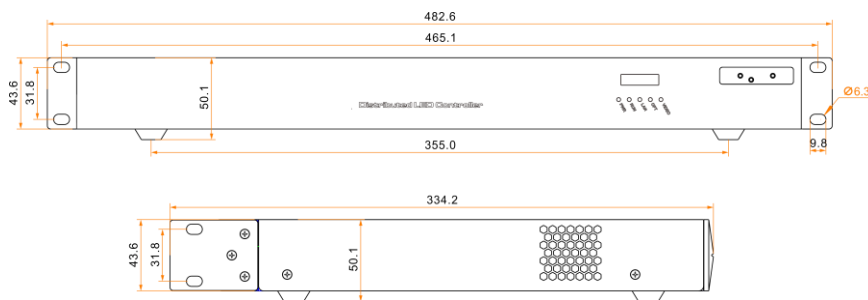

Tolerance: ± 0.3 Unit: mm

Specifications

Overall Specifications				
Model		MG200	MG201	MGT600
Electrical Specifications	Power connector	DC12V 3A		100-240V~, 50/60Hz, 2A~0.8A
	Max power consumption	17 W		27W
Operating Environment	Temperature	-10°C to +60°C		
	Humidity	0% RH to 85% RH, non-condensing		
Storage Environment	Temperature	-20°C to +70°C		
	Humidity	0% RH to 95% RH, non-condensing		
Physical Specifications	Dimensions	211.7 mm x 258.2 mm x 43.6 mm		482.6 mm x 334.2 mm x 50.1 mm
Packing Information	Accessories	1x Certificate of Approval, 1x Safety Manual		
		10x Phillips screws, 1x hanging bracket, 1x connecting piece, 4x foot pads, 1x power adapter, 1x HDMI cable, 1x assembly instructions		1x Power cord

Overall Specifications				
		1x USB cable	-	
	Net weight	1.8 kg	1.8 kg	4 kg
	Gross weight	2.8 kg	2.7 kg	6.3 kg
	Packing box dimensions	695 mm x 458 mm x 385 mm		565 mm x 450 mm x 175 mm
		 Note Each box contains up to 6 devices.		

Video Source Features

Input Connector	Bit Depth		Max Input Resolution
• HDMI 1.3	8bit	RGB4:4:4	2048×1080@60Hz
		YCbCr4:4:4	4096×1080@30Hz
		YCbCr4:2:2	
	10bit	RGB4:4:4	2048×1080@30Hz
		YCbCr4:4:4	
		YCbCr4:2:2	4096×1080@30Hz

Input and Output Resolutions

Input Resolutions

Standard Resolutions		Input Connector
Resolution	Frame Rate (Hz)	HDMI 2.0
3840×1080p	30	Forced
2048×1152p	30/60	Forced
2048×1080p	30/48/50/59.94/60	√
1920×1200p	50/59.94/60	√
1920×1080p	30/48/50/59.94/60	√
1792×1280p	60	√

Standard Resolutions		Input Connector
Resolution	Frame Rate (Hz)	HDMI 2.0
1680×1050p	60	√
1600×1200p	48/50/59.94/60	√
1600×900p	48/50/59.94/60	√
1440×900p	60/75/85	√
1400×1050p	48/50/59.94/60/75	√
1360×768p	60	√
1280×1024p	48/50/59.94/60/75/85	√
1280×960p	50/59.94/60/85	×
1280×800p	50/59.94/60	√
1280×768p	48/50/59.94/60/75	×
1280×720p	48/50/59.94/60	×
1152×864p	75	×
1024×768p	48/50/59.94/60/75/85	×
800×600p	59.94/60/75/85	×

- √: The current connector supports the standard resolution and frame rate settings.
- ×: The current connector does not support the standard resolution and frame rate settings.

Output Resolutions

Standard Resolutions		HDMI 1.3
Resolution	Frame Rate (Hz)	Default resolution: 1920×1080@60Hz
3840×1080p	30	√
2304×1152p	60	√
2048×1152p	30/60	√

Standard Resolutions		HDMI 1.3
Resolution	Frame Rate (Hz)	Default resolution: 1920×1080@60Hz
2048×1080p	30/48/50/59.94/60	√
1920×1200p	50/59.94/60	√
1920×1080p	30/48/50/59.94/60	√
1792×1280p	60	√
1680×1050p	60	√
1600×1200p	48/50/59.94/60	√
1600×900p	48/50/59.94/60	√
1440×900p	60/75/85	√
1400×1050p	48/50/59.94/60/75	√
1364×768p	50/59.94/60	√
1364×1024p	48/50/59.94/85	√
1360×768p	60	√
1280×1024p	48/50/59.94/60/75/85	√
1280×960p	50/59.94/60/85	√
1280×800p	50/59.94/60	√
1280×768p	48/50/59.94/60/75	√
1280×720p	48/50/59.94/60	√
1152×864p	75	√
1024×768p	48/50/59.9	√

- √: The current connector supports the standard resolution and frame rate settings.
- x: The current connector does not support the standard resolution and frame rate settings.

Notes and Cautions

FCC Caution

Any changes or modifications not expressly approved by the party responsible for compliance could void the user's authority to operate the equipment.

This device complies with part 15 of the FCC Rules. Operation is subject to the following two conditions: (1) This device may not cause harmful interference, and (2) this device must accept any interference received, including interference that may cause undesired operation.

Note: This equipment has been tested and found to comply with the limits for a Class A digital device, pursuant to part 15 of the FCC Rules. These limits are designed to provide reasonable protection against harmful interference when the equipment is operated in a commercial environment. This equipment generates, uses, and can radiate radio frequency energy and, if not installed and used in accordance with the instruction manual, may cause harmful interference to radio communications. Operation of this equipment in a residential area is likely to cause harmful interference in which case the user will be required to correct the interference at his own expense.

Others

This is Class A product. In a domestic environment, this product may cause radio interference in which case the user may be required to take adequate measures.

Copyright © 2023 Xi'an NovaStar Tech Co., Ltd. All Rights Reserved.

No part of this document may be copied, reproduced, extracted or transmitted in any form or by any means without the prior written consent of Xi'an NovaStar Tech Co., Ltd.

Trademark

 is a trademark of Xi'an NovaStar Tech Co., Ltd.

Statement

Thank you for choosing NovaStar's product. This document is intended to help you understand and use the product. For accuracy and reliability, NovaStar may make improvements and/or changes to this document at any time and without notice. If you experience any problems in use or have any suggestions, please contact us via the contact information given in this document. We will do our best to solve any issues, as well as evaluate and implement any suggestions.

| [Official website](http://www.novastar.tech)
| www.novastar.tech

| [Technical support](mailto:support@novastar.tech)
| support@novastar.tech